



MLT 3000

THE FUTURE-PROOF
INVESTMENT

made by MAHA
 made
in
Germany



“STAND ALONE” VERSION

WITH PC CONNECTIVITY

PRECISE MEASUREMENT TECHNOLOGY FOR CURRENT AND FUTURE LIGHTING SYSTEMS



01 State-of-the-art lighting systems with variable cut-off are no challenge for the MLT 3000.

02 Within fractions of a second, the integrated CPU analyses the contour of the cut-off line

Pronounced blue fringing in the area of the cut-off line is reliably evaluated by the integrated control electronics.

HIGHLY USER-FRIENDLY AND POWERFUL



03 A rechargeable battery integrated into the base of the unit supplies the MLT 3000 with power for an entire working day and ensures a stable stand thanks to the low centre of gravity.

Thanks to the weight reduction due to the relocation of the battery, the light collection box runs very smoothly and precisely on the column.

04 The unit is aligned with the vehicle by means of a mirror or, optionally, by using the laser pointer.

ELECTRONIC LEVELLING COMPENSATES FOR UNEVENNESS

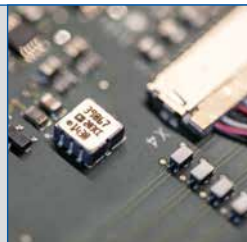

05 The electronic levelling system compensates for unevenness in the set-up area and is thus an absolute highlight of the MLT 3000. A deviation of only a few millimeters already results in an incorrect assessment of the measurement results. The deviations detected by the position sensor are automatically compensated by the MLT 3000 software, thus avoiding incorrect measurements.

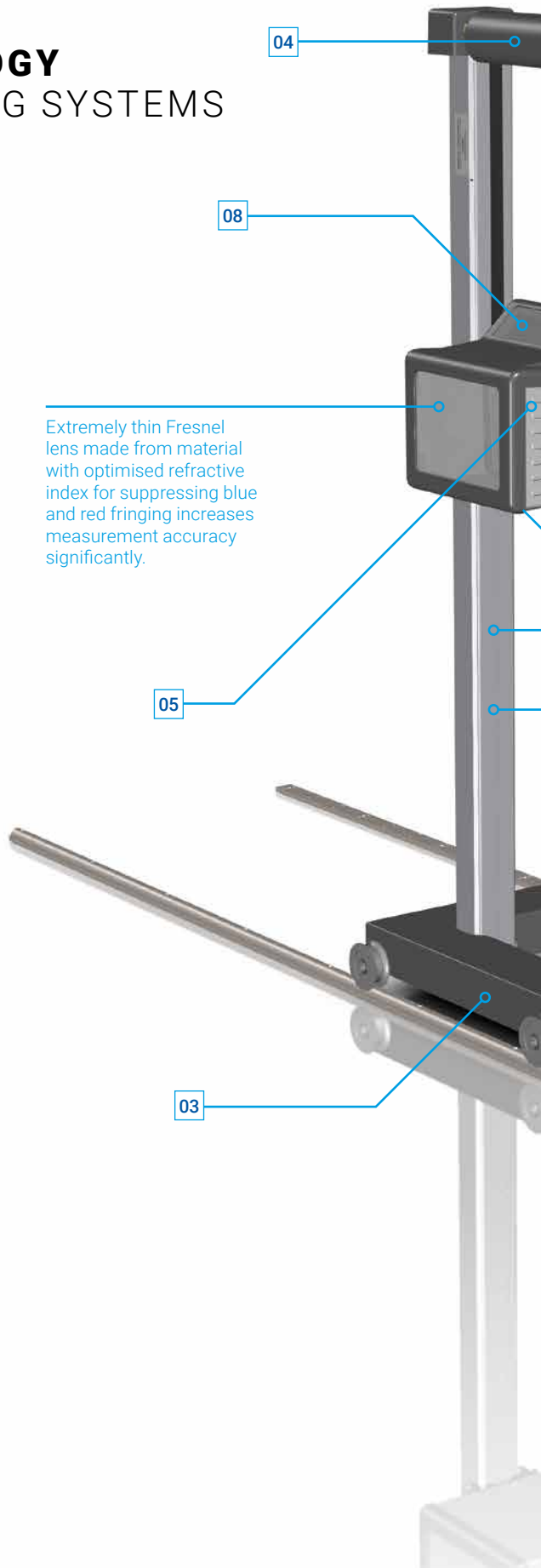

08 Extremely thin Fresnel lens made from material with optimised refractive index for suppressing blue and red fringing increases measurement accuracy significantly.

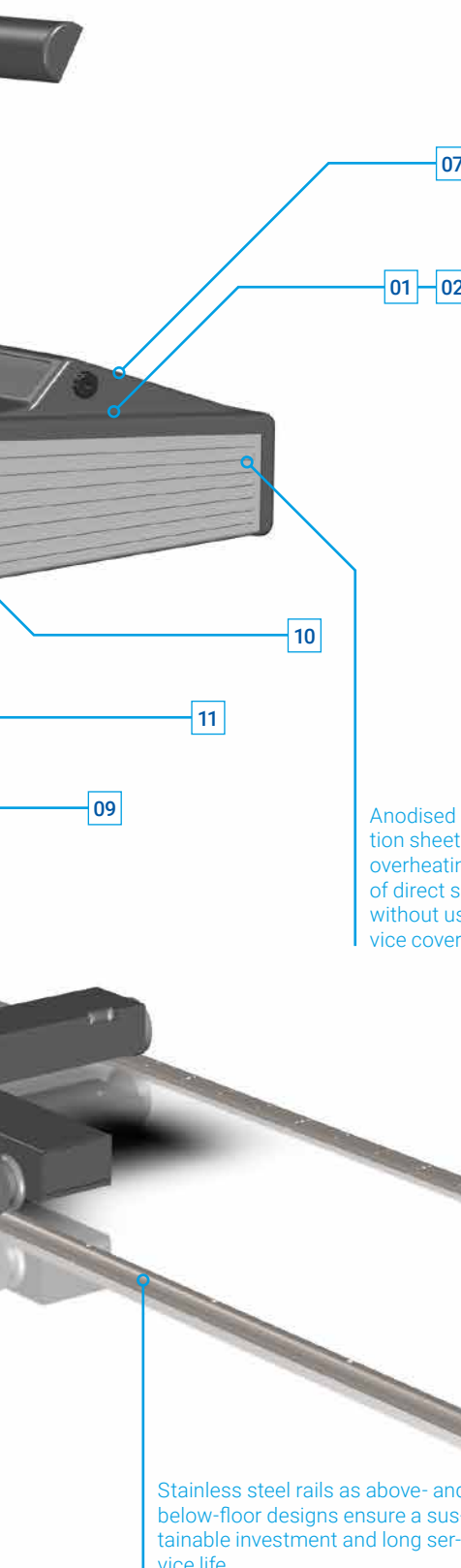

Anodised heat deflection sheet to prevent overheating as a result of direct sunlight even without use of the device covering hood.

Stainless steel rails as above- and below-floor designs ensure a sustainable investment and long service life.

WELL-ESTABLISHED OPERATING CONCEPT



Intuitive operator guidance is ensured via the 7" touch display.



The optionally available optical adjustment aid in the front of the unit facilitates headlight setting in the horizontal and vertical directions thanks to its LED display.



The MLT 3000 offers optional Bluetooth or cable connection. Networking with a test lane is possible at any time thanks to the proven EUROSISTEM software.

NON-WEARING PRECISION GUIDE COLUMN



The MLT 3000 is equipped with a non-wearing precision guide column.



The vertical guide of the light collection box is particularly maintenance-free and smooth-running thanks to its ball-bearing mounted guide rollers.



A counterweight integrated into the guide column allows the light collection box to be positioned with smooth, effortless movements.

STRAIGHTFORWARD UPDATES FOR FUTURE LIGHTING SYSTEMS

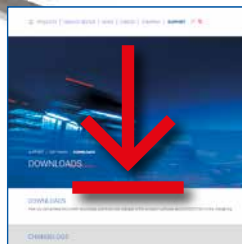

Given that vehicle manufacturers can be expected to produce further headlight innovations in future, constant adjustments to the tester software are an absolute necessity. MAHA makes the required updates available for download on its website. These updates can be installed quickly and easily via a web interface, directly from a networked PC or using a USB stick. This makes the MLT 3000 a future-proof investment.



RECOMMENDATIONS

FOR THE HEADLIGHT TEST STATION

The headlight tester and test station function as a single measurement unit for identifying the cut-off line. The MLT 3000 surpasses all requirements here. Test stations need to be designed in such a way that incorrect measurement results can be ruled out.



- The inclination* of the base surfaces for the headlight tester and the vehicle should not exceed 1.5%.
- The difference between the inclinations of the left and right driving surface should be no greater than 0.5%. In particular, the surfaces must not slope in opposite directions.
- At all other measurement points of the driving surfaces, the unevenness* should not exceed 3 mm/m.

TECHNICAL DATA

Application range	Testable headlight types	Paraboloid, projection system and free form
	Testable light sources	Bilux, Halogen, XENON and LED
Measuring range	above	Hotspot 0 – 800 mm / 10 m (0 – 8 %) Pitch angle 0 – 300 mm / 10 m (0 – 3 %)
	below	0 – 700 mm / 10 m (0 – 7 %)
	left	0 – 1000 mm / 10 m (0 – 10 %)
	right	0 – 1000 mm / 10 m (0 – 10 %)
	Height of light center	240 – 1500 mm
	Measuring distance	100 – 500 mm
Intensity	Luminosity	0 – 125,000 cd (Candela)
	Illuminance	0 – 200 lx (Lux)
Error margins	Intensity	+/- 5 %
	Deviation from an axis	+/- 5'
Working range	Temperature	+5 – +40°C
	Relative humidity	20 – 80 %
	Power supply	100 – 240 V, 50/60 Hz AC / 12 V DC

* The inclination of the test area corresponds to how much the test area tilts away from the horizontal base line, expressed as an angle. Unevennesses are height deviations with regard to the line of inclination, measured at various points.

BR380701-en-06 - Subject to technical changes without notice. The illustrations include options not part of the standard scope of delivery.

MAHA Maschinenbau Haldenwang GmbH & Co. KG
Hoyen 20
87490 Haldenwang
Germany

maha.de