



THE MOBILE TEST LANE

SELF-POWERED AND
QUICKLY READY

made by MAHA
made
in
Germany



The test container MTL 15 is fully self-sufficient due to an optionally available, fully integrated power generator. Equipped with a hydraulic lowering device, including cable remote control, the test system can be set up within 15 minutes and is ideal for relocation.

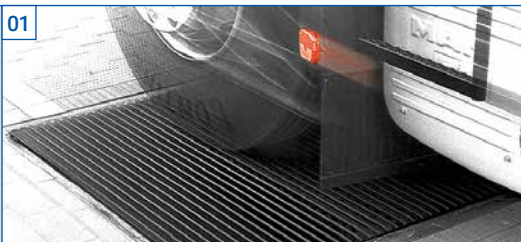

The side-slip tester MINC II EURO ensures that the axle geometry is inspected within seconds once the test vehicle passes over it (up to 15.0 t axle load) as well as a fully automatic evaluation of the deviation in m/km.



The axle damping test bench MSD 3000 is characterised by a fast and precise mechanical testing of the axle damping (Lehr's principle). The fully automatic test sequence, including the calculation of axle and vehicle weight, saves time and allows a reliable assessment of the axle damping.



The test-lane-compatible roller brake tester MBT 7000 is designed for the brake testing of vehicles with axle loads up to 18.0 t and is ideal for vehicles diagnostics in situations of high vehicle throughput.

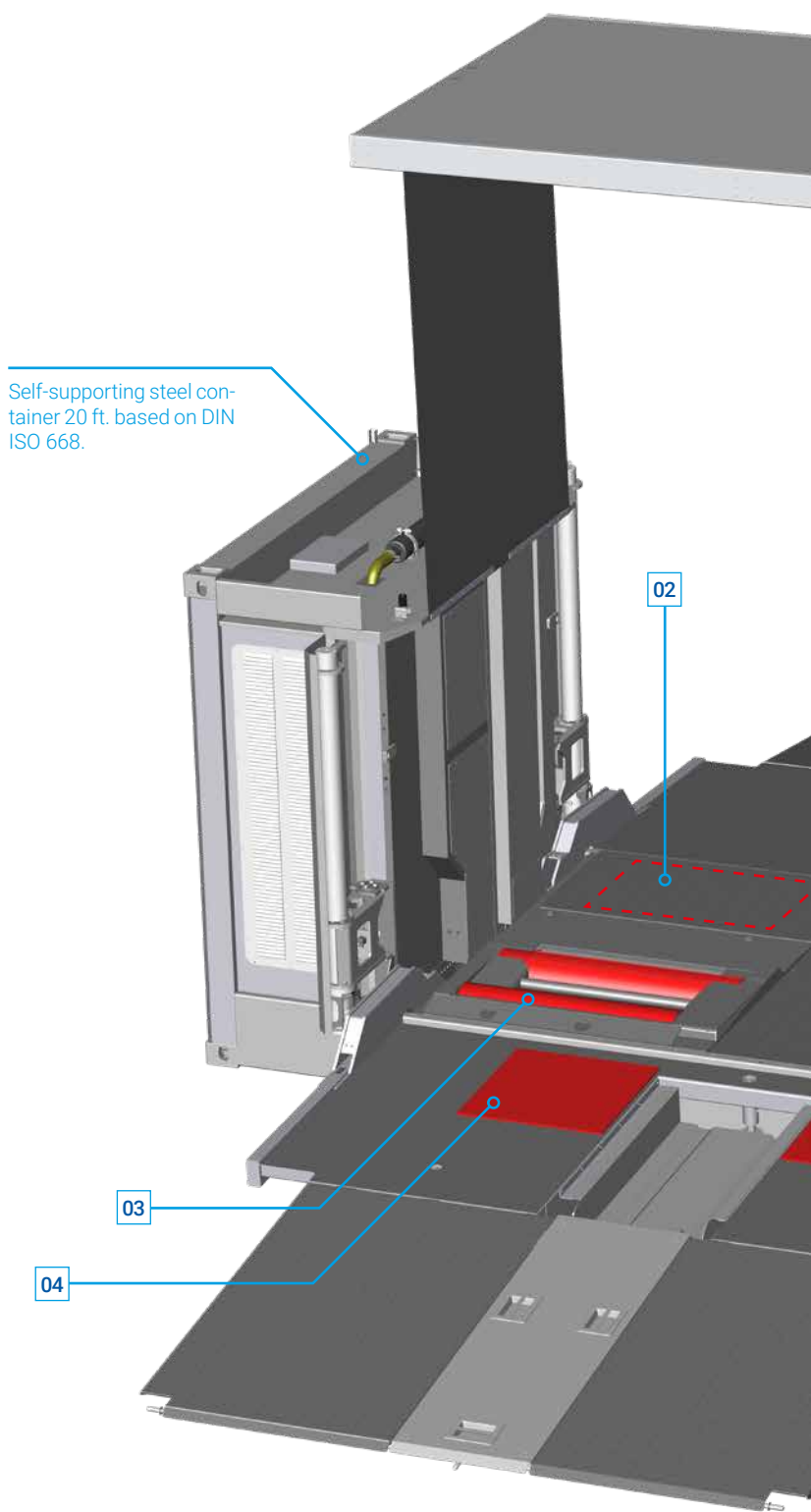



360° rotating device for test container for easy positioning on site (optional)

Hydraulically lifting roof with weather protection.

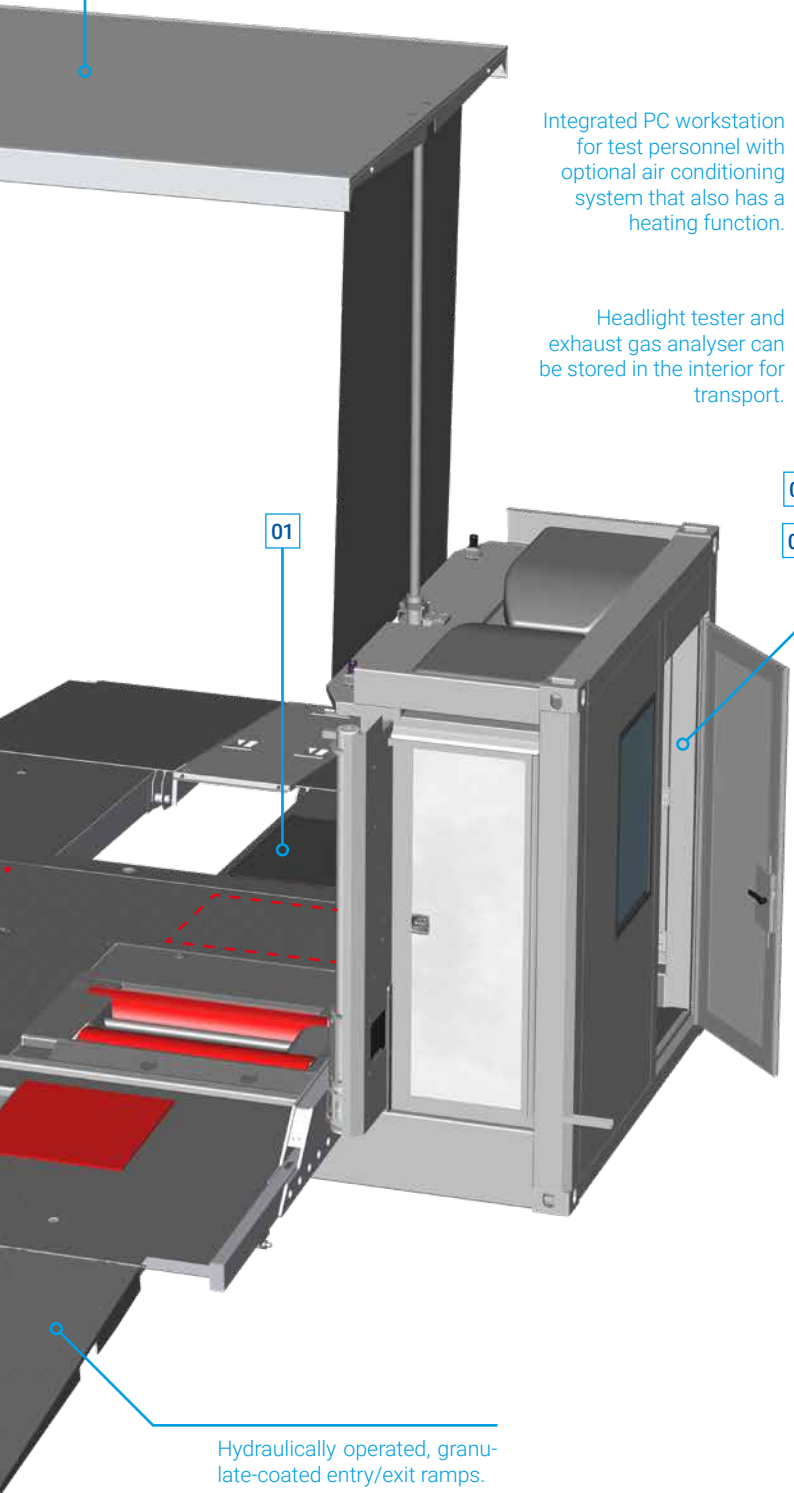

Integrated PC workstation for test personnel with optional air conditioning system that also has a heating function.

Headlight tester and exhaust gas analyser can be stored in the interior for transport.

01

05

06

Hydraulically operated, granulate-coated entry/exit ramps.



04

The axle play tester LMS 20.0 is intended for the reliable determination of defects and wear on steering parts, wheel bearings, shock absorbers and suspension by lateral and longitudinal movement of the test plates in opposite directions. An automatic mode as well as other different operating modes ensure the uncomplicated operability of the LMS 20.0.



05

The MLT 1000 and MLT 3000 headlight testers are used to quickly and objectively check and adjust vehicle headlights. Irregularities in the installation area are corrected by electronic level compensation (MLT 3000 only).



06

Our MET 6 series exhaust gas analyser are designed for the measurement of petrol- and diesel-powered vehicles. In addition, low weight, compact design and short warm-up time ensure easy handling.

TWIN SCISSORS LIFT

TWIN F IV 3.5 – THE SPACE-SAVING SOLUTION

HIGH CONVENIENCE OF OPERATION
WITH SPACE-SAVING DESIGN

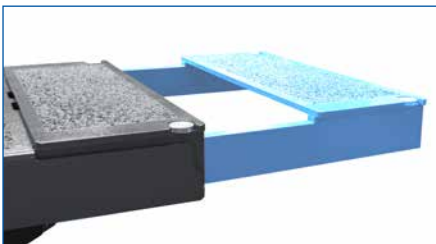

Support plates can be continuously extended from 1550 mm to 2100 mm. This makes it possible to lift smaller vans.



Maintenance-free cylinder raising support: full lifting capacity is effective at lower heights already. Smooth pick-up and lowering of load with reduced speed.



Double safety provision with two lifting cylinders on each scissors side, fully hydraulic system, no safety latch and no air pressure needed for operation.

BR02330T-en 01 - Subject to technical changes without notice. The illustrations include options not part of the standard scope of delivery.

MAHA SE & Co. KG
Hoyen 20
87490 Haldenwang
Germany

maha.de