



MA STAR

Two Post Lifts

Original Operating Instructions

BA364501-en

MA STAR 3.5 A STOCK
MA STAR 3.5 S STOCK
MA STAR 3.5 A
MA STAR 3.5 S
MA STAR 3.5 A BMW
MA STAR 3.5 A MB
VAS 771 043 (MA STAR 3.5 A)

MA STAR 5.5 STOCK
MA STAR 5.5
MA STAR 5.5 MB
VAS 771 045 (MA STAR 5.5)

MA STAR 6.5 STOCK
MA STAR 6.5
MA STAR 6.5 MB

© MAHA SE & Co. KG

The reproduction, distribution and utilisation of this document as well as the communication of its contents to others without explicit authorisation is prohibited. Offenders will be held liable for the payment of damages. All rights reserved in the event of the grant of a patent, utility model or design.

The contents have been checked with great care; however, errors cannot be fully excluded. Illustrations are examples and may differ from the original product. Subject to technical change without notice.

Manufacturer

MAHA SE & Co. KG
Hoyen 20 | 87490 Haldenwang | Germany

 +49 8374 585-0

 maha@maha.de

 www.maha.de

Service

MAHA SERVICE CENTER
Maybachstraße 8 | 87437 Kempten | Germany

 +49 8374 585-100

 service@maha.de

 www.mahaservicecenter.de

Dear Customer,

MAHA is one of the world's leading manufacturers of testing and lifting technology and places particular emphasis on quality and performance. The company's concept includes the development, manufacture and sale of products for use in automotive workshops, by vehicle manufacturers and testing organisations.

MAHA's claim is to also be a leader in the areas of reliability, safety and sustainability – this can be seen in many details that have been developed with these aspects in mind.

We are convinced that you will be more than satisfied with the quality and performance of our products for many years. With the purchase of our products you will also receive professional assistance in case of need for service and repair.

Please remember to keep these operating instructions in a safe place. Accurately following their contents will significantly extend the life of your product and also increase its resale value. If you sell your product, please also pass on the operating instructions.

MAHA is constantly working on the further development of all products and therefore reserves the right to make changes, e.g. in shape and appearance, without prior notice.

Extensive accessories, useful assembly material and auxiliary materials are available for our products. For further information, please ask your dealer or your MAHA contact person at any time.

Thank you for choosing a MAHA product!

Contents

1	General Safety Instructions	5
1.1	Introduction	5
1.2	Symbols and Signal Words	5
1.2.1	Personal Injury	5
1.2.2	Property Damage	5
1.3	What to Do in the Event of Defects or Malfunctions	6
1.4	What to Do in the Event of an Accident	6
1.5	Requirements for the Operating Personnel.....	6
1.6	Requirements on Service Personnel.....	6
1.7	Intended Use	7
1.8	Inappropriate Use	7
2	Description	8
2.1	Service Life.....	8
2.2	Overall View with Components.....	8
2.3	Technical Data	9
2.3.1	Installation Diagram	11
2.3.2	Danger Zone	11
3	Transport, Handling and Storage	12
3.1	Safety Instructions.....	12
3.2	Scope of Delivery	12
3.3	Packaging Information	13
3.3.1	Dimensions and Weight	13
3.3.2	Centre of Gravity of the Packaged Lift.....	13
3.4	Transport and Handling.....	13
3.5	Storage	14
4	Operation	14
4.1	Safety Instructions.....	14
4.2	Operation and Operating States	16
4.3	Preparing the Lifting Operation.....	17
4.3.1	Establishing Operational Readiness	17
4.3.2	Positioning the Vehicle	17
4.3.3	Positioning the Support Arms and Pick-up Plates	18
4.4	Raising and Lowering Cycles	19
4.4.1	Inspecting the Load Pick-up Points and Support Arm Locks	19
4.4.2	Lashing the Vehicle	19
4.4.3	Continuing the Lifting Process	20
4.4.4	Lowering Process.....	20
4.5	Driving the Vehicle off the Lift.....	20
4.6	Form-Fit Adapters	21
4.7	Support Disc Raisers	21
4.8	Wheel Engaging Supports (MA STAR 5.5 and 6.5 only)	21
4.9	Special Prism Support – Plug-in System	23
4.10	Referencing the Control System	23
5	Troubleshooting.....	24

5.1	Troubleshooting Table	24
5.2	Emergency Lowering	26
5.2.1	Electrical Emergency Lowering	26
5.2.2	Mechanical Emergency Lowering	26
6	Inspection Daily before Starting Work	27
6.1	Cables and Actuators	27
6.2	Emergency Stop.....	27
6.3	Limitation of the Support Arm Extensions	27
6.4	Function of the Support Arm Lock.....	28
6.5	Load Supports.....	29
7	Servicing by the Operator	30
7.1	Safety Instructions.....	30
7.2	Lubrication	30
7.2.1	Lubrication Points and Lubricants	30
7.2.2	Lubricating the Spindle and the Load Nut	31
7.2.3	Greasing the Slide Tracks	32
7.2.4	Greasing the Arm Extensions	32
7.2.5	Lubricating the Thread of the Support Discs.....	33
7.2.6	Lubricating the Spindle Bearing (MA STAR 5.5 / 6.5 only)	33
7.3	Checking the Load Nut's Wear Indicator	34
8	Extended Warranty.....	36
9	Decommissioning, Dismantling and Disposal.....	36
10	Declaration of Conformity	36

1 General Safety Instructions

1.1 Introduction

- These operating instructions must be read carefully and understood before work commences.
- Please observe the specific safety information provided for the respective sections of the operating instructions.
- Adhering to the procedures, sequences and corresponding safety instructions is essential.
- A printed copy of the operating instructions must always be kept by the lift.
- The relevant regulations regarding accident prevention and health and safety must be observed.

1.2 Symbols and Signal Words

1.2.1 Personal Injury



DANGER

indicates an immediate hazard which, if not avoided, will result in death or severe personal injury.



WARNING

indicates a potential hazard which, if not avoided, could result in death or severe personal injury.



CAUTION

indicates a potential hazard which, if not avoided, could result in moderate or minor personal injury.

1.2.2 Property Damage

NOTICE

indicates a potentially harmful situation which, if not avoided, could result in damage to the equipment or surrounding objects.

1.3 What to Do in the Event of Defects or Malfunctions

- If a malfunction occurs, e.g. uncontrolled raising and lowering or in the case of load-bearing components of the structure becoming deformed, immediately lower the lift to the ground to its initial position or support the structure.
- Turn off the main switch and secure against unauthorised use.
- Contact service team.

1.4 What to Do in the Event of an Accident

- Notify first aiders, the ambulance service and/or immediate care doctor:
 - Where did the accident happen (address, workshop, ...)?
 - What happened?
 - How many are injured?
 - What injuries have occurred?
 - Who is reporting the accident?
- Keep calm and answer questions.

1.5 Requirements for the Operating Personnel

All persons involved in the operation of the equipment must:

- be 18 years of age or older,
- have the mental and physical capacity for their role,
- be demonstrably trained and instructed in writing in the operation of the equipment,
- have read and understood the operating instructions, and in particular the instructions on the procedure in the event of a malfunction,
- show knowledge and experience in handling the equipment and the dangers posed,
- have had certified training regarding safety regulations.

1.6 Requirements on Service Personnel

Persons who are entrusted with the installation, maintenance and/or dismantling of the equipment must in addition:

- be demonstrably trained and instructed in the required work,
- can provide evidence of appropriate qualification for work on the electrical system of the equipment (e.g. as a qualified electrician),
- be able to demonstrate expertise for vehicle lifts. This includes sufficient knowledge in the field of lifts and the relevant statutory occupational health and safety regulations, accident prevention regulations and generally ac-

cepted rules of technology to be able to assess the safe working condition of the lift to be tested.

- Qualified persons shall not only consider the current condition of the lift during the inspection. They must also be able to estimate how the lift and its structural parts will behave under operational conditions in the sequence and how wear, aging and the like will affect the safety of the lift.

1.7 Intended Use

- This lift is exclusively intended for the safe lifting and lowering of passenger cars and commercial vehicles within the scope of service and repair work.
- In compliance with the load distribution regulations of DIN EN 1493, the permitted load capacity on the identification plate must not be exceeded.
- Only vehicles which are suitable for the lifting equipment due to their shape and the positioning of their lifting points may be lifted.
- The lift is designed for a maximum of 6 lifting cycles with nominal load per hour.
- The lift must only be operated in the temperature range 5 to 40 °C at a maximum humidity of 50% (at 40 °C).
- The lift must be protected from direct weather conditions at all times.
- The lift must only be operated on level and sufficiently load-bearing ground (see the foundation specifications!).
- The lift must not be modified without express written permission from the manufacturer. Non-compliance invalidates the declaration of conformity.

1.8 Inappropriate Use

- The lifting of other vehicles and loads is not permitted.
- Carrying of passengers is not permitted.
- Lifting the load with an additional hoist is prohibited.
- The lift must not be operated in potentially explosive and flammable operation rooms or in damp rooms (e.g. washing facilities).

2 Description

2.1 Service Life

The lift has been tested according to DIN EN 1493 and designed for 22,000 lifting cycles under nominal load.

2.2 Overall View with Components

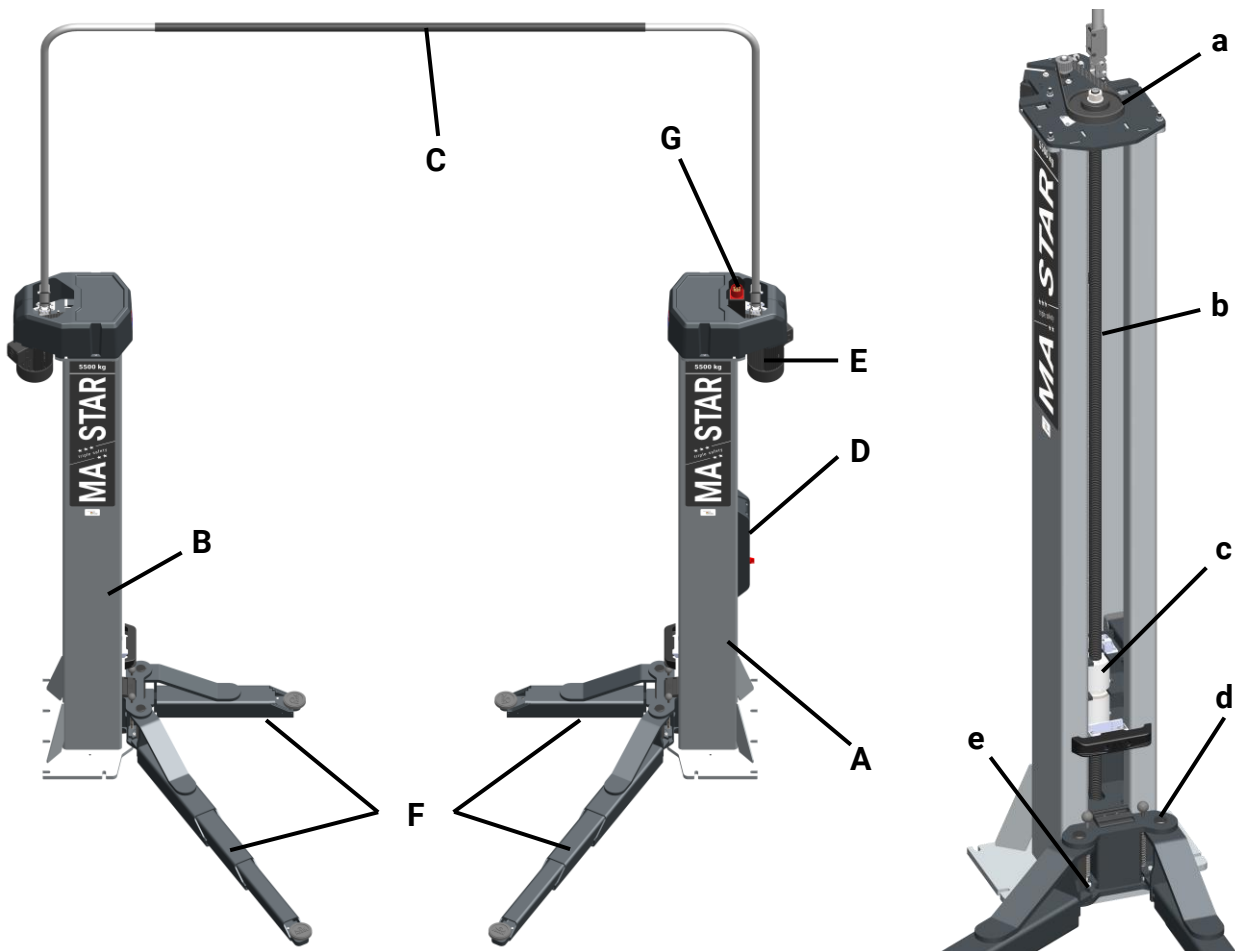

- A Control column
- B Counter column
- C Cable bridge
- D Control unit
- E Drive motor
- F Support arms
- G Connector plug

- a Toothed belt drive
- b Trapezoidal spindle
- c Nut package
- d Lifting carriage (with support arms)
- e Support arm locking device

2.3 Technical Data

MA STAR model	3.5 A	3.5 S	3.5 A + VZ 971652	3.5 A + VZ 971653
Rated load capacity [kg]	3500		3000	2500
Overall height HG [mm]	4499			
Overall width BG [mm]	3591	4100	3841	4391
Clear height HL [mm]	4452			
Full travel HW [mm]	1885			
Lifting height max. HO [mm]	1995			
Lower swivel height HU [mm]	100			
Adjustment range support plate HAT [mm]	80...110			
Extension range support arm short LT [mm]	630...1240			
Swivel range support arm short [°]	180	102.5	180	
Extension range support arm long [mm]	920...1490	---	920...1490	
Swivel range support arm long [°]	102.5	---	102.5	
Support range [mm]	---			
Inside columns BL [mm]	2660	2697	max. 3060	max. 3460
Outside columns BA [mm]	3241	3097	max. 3641	max. 4041
Outside base plates [mm]	3351	3307	max. 3751	max. 4151
Inside base plates BGi [mm]	2643	2707	max. 3043	max. 3443
Drive-through width BH [mm]	2400	2400	max. 2800	max. 3200
Operating temperature [°C]	+5...+40			
Net weight of both columns without / with packaging [kg]	650 / 740	635 / 725	650 / 740	
Adhesive mortar for anchor rod	HILTI HIT HY 200-A			
Anchor rod	HAS U 5.8 M16			
Required minimum concrete quality	C20/25 (DIN EN 1992)			
Drive power [kW]	2x 3.0			
Duty cycle	S3-20%			
Lifting/lowering time [s]	40			
Packaging dimensions (L x W x H) [mm]	2925 x 1100 x 710			

MA STAR model	5.5		6.5		
Rated load capacity [kg]	5500		6500		
Overall height HG [mm]	5193		5193		
Overall width BG [mm]	4000	4100	4250	4192	5193
Clear height HL [mm]	5146		5146		
Full travel HW [mm]	2000		1950		
Lifting height max. HO [mm]	2115		2065		
Lower swivel height HU [mm]	120		144		
Adjustment range support plate HAT [mm]	85...115		85...115		
Extension range support arm short LT [mm]	---		---		
Swivel range support arm short [°]	---		---		
Extension range support arm long [mm]	---		---		
Swivel range support arm long [°]	100		100		
Support range [mm]	965...1845		1037...1987		
Inside columns BL [mm]	2849	2949	3099	2973	3127
Outside columns BA [mm]	3479	3579	3729	3603	3753
Outside base plates [mm]	3689	3789	3939	4043	4193
Inside base plates BGi [mm]	2729	2829	2979	2813	2963
Drive-through width BH [mm]	2530	2630	2780	2630	2780
Operating temperature [°C]	+5...+40				
Net weight of both columns without / with packaging [kg]	1320 / 1525		1520 / 1780		
Adhesive mortar for anchor rod	HILTI HIT HY 200-A				
Anchor rod	HAS U 5.8 M16		HAS U 5.8 M20		
Required minimum concrete quality	C20/25 (DIN EN 1992)				
Drive power [kW]	2x 4.0				
Duty cycle	S3-20%				
Lifting/lowering time [s]	40		44		
Packaging dimensions (L x W x H) [mm]	2 packages each 3185 x 760 x 960		2 packages each 3185 x 800 x 1100		

MA STAR model	Power supply	On-site back-up fuse	RCD
3.5 A/S	3x 400 V/50 Hz + N + PE	C16A	30 mA
	3x 230 V/50 Hz + N + PE	C25A	
	3x 400 V/60 Hz + N + PE	C16A	
	3x 230 V/60 Hz + N + PE	C25A	
5.5 / 6.5	3x 400 V/50 Hz + N + PE	C32A	

2.3.1 Installation Diagram

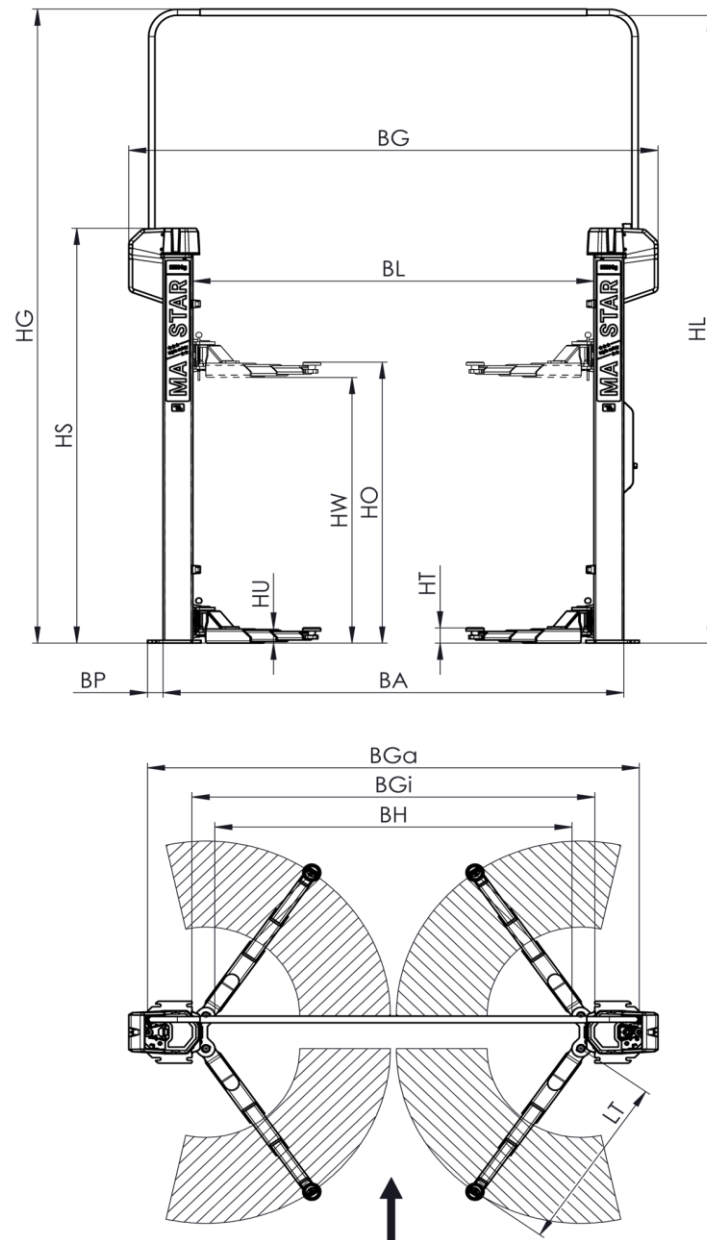

2.3.2 Danger Zone

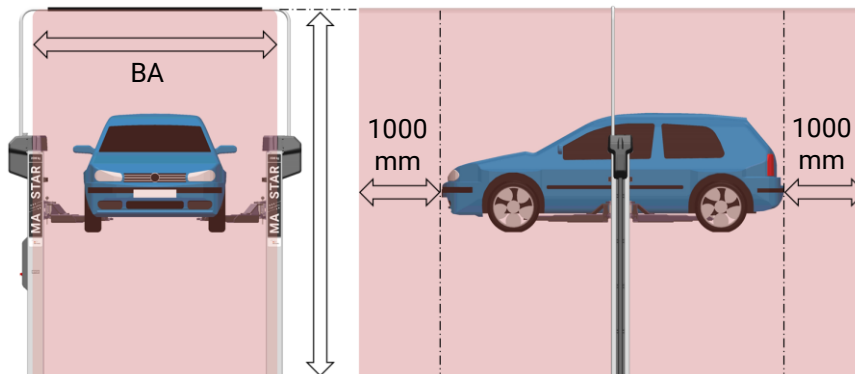

3 Transport, Handling and Storage

3.1 Safety Instructions



WARNING

- Wear personal protective equipment.
 - Standing under a suspended load is prohibited.
 - The transport and storage of packages is only permitted using original transport racks. Observe the max. stacking height.
 - Before removing the packaging straps, secure the packages against falling and maintain a safe distance. Rebounding packaging straps can cause injuries!
 - Only lift and set up the lift columns using the marked connection points. Pay attention to the centre of gravity (marked COG).
 - Only use lifting equipment and slings that are suitable in terms of type and permitted load capacity.
 - Always ensure that the parts to be transported are suspended or loaded properly and in a fall-proof manner, taking into account their size, weight and centre of gravity. Observe transport regulations.
-

3.2 Scope of Delivery

Lifts with 3.5 t load capacity are shipped ex works in one package as standard, lifts with higher load capacity in two packages. Content:

- 2 columns, screwed in racks
- 2 covers
- 1 instruction manual
- 2 sets (2 pieces each) support arms
- 4 lock elements
- 4 support discs
- 1 set impact protectors for support arms
- 1 set connector cable
- 1 cable bridge with mounting parts
- Spindle oil 500 ml
- Optional accessories

The number of delivered packages and contents must be checked for damage and completeness according to the order confirmation. Any transport damage must be documented immediately and reported to the delivery carrier.

3.3 Packaging Information

3.3.1 Dimensions and Weight

MA STAR model	3.5 A	3.5 S	5.5	6.5
Dimensions [mm]	2925 x 1100 x 710		3185 x 760 x 960	3185 x 800 x 1000
Weight approx. [kg]	740	725	2x 800	2x 900

3.3.2 Centre of Gravity of the Packaged Lift

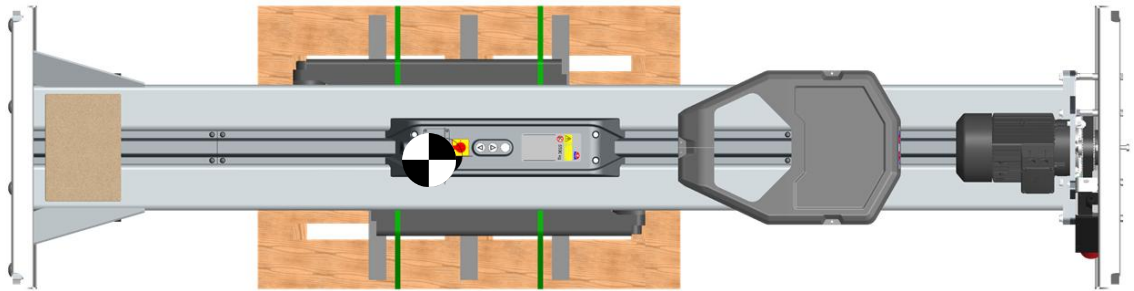

3.4 Transport and Handling

The transport and handling of the lift is only permitted using the original transport racks. The pick-up points shown below must be used for the loading and unloading of the packaged lift.

IMPORTANT: Strapping of the columns is not permitted!

The dimensions and centre of gravity of the packaged lift are shown in the section "Packaging Information".

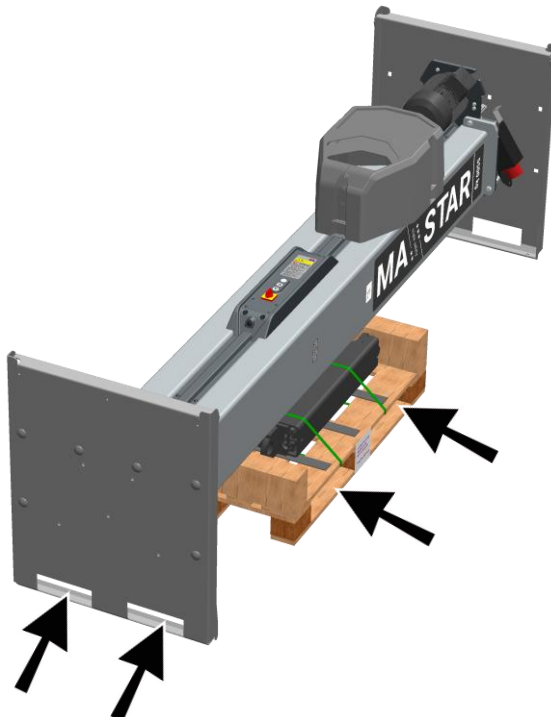

3.5 Storage

The packages must be stored in a covered location and protected from direct sunlight. They must be stored at low humidity and at a temperature between 0 °C and +40 °C.

The lifts may only be stacked in the original transport racks, the max. stacking height is two transport racks (see also section "Transport and handling").

Packaging waste must be disposed of in accordance with applicable environmental regulations.

4 Operation

4.1 Safety Instructions









WARNING

- Observe the detailed operating instructions.
- Comply with legal accident prevention regulations.
- Wear personal protective equipment.
- Perform a visual and functional check before starting work each day.
- Defects must be corrected immediately in a competent manner.
- The permissible load capacity according to the type plate must not be exceeded.
- Only vehicles suitable for the lifting equipment due to their shape and the positioning of their pick-up points may be lifted.
- Operation of the lift is only permissible with mounted and intact protective covers and safety devices.
- Never touch moving parts.
- Never use additional lifting gear for an already raised load.
- Before driving a vehicle onto the lift, the support arms must be in their lowered starting position and moved backwards completely. Otherwise damage to the equipment may occur.
- Driving onto the lift should be at walking pace only and as close to the centre of the columns as possible.
- Vehicles may only be lifted with support arm locks intact and undamaged support discs. Risk of vehicle falling and causing personal injury.
- Support disc raisers may only be used in their single form. A combination of support plate elevations per support plate/arm is not permitted.
- Maintain a safe distance from the vehicle and lift in all directions.
- Keep the movement range of the load and lift free from obstacles. Use a guide if visibility is restricted.
- The vehicle doors must be closed during lifting and lowering.

- The vehicle can be strapped to the lift if necessary. Shifts in the centre of gravity of the vehicle through installation/removal of heavy vehicle parts may otherwise lead to the vehicle sliding off.
 - After raising just off the floor, check that the vehicle has been picked up securely and that the support arms are locked correctly. If necessary, lower the vehicle and pick up again.
 - The transport of passengers is prohibited.
 - Climbing up the lifted vehicle or the lift is prohibited.
 - There should not be any people or objects within the safety zone of the lift and the load during the lifting and lowering process.
 - Monitor the load and the lift during lifting and lowering. In the event of an irregularity, the emergency stop button (main button on the main operation column or the emergency stop button on the second control unit on the opposite column), must be pressed immediately.
ATTENTION: The 230V plug sockets on the operation unit(s) still carry power even after the system has been switched off!
 - There is a risk of tripping on floor-mounted lifting equipment and on the foundation anchor of the lift.
 - Parts must not be placed on the lift or the vehicle to be lifted.
 - Keep the lift and the working area clean. ATTENTION: Risk of slipping on oily surfaces!
 - Protect all parts of the electrical system from moisture.
 - Be careful when running vehicle engines. ATTENTION: Risk of poisoning!
 - Changes to or overriding of the safety features installed is prohibited!
 - Inching mode should be avoided to prevent the motor from overheating. Instead, drive briskly through.
 - During work breaks and at the end of the working day, the system must be switched off and secured against unauthorised use.
-

4.2 Operation and Operating States

The lift has been fitted with an intuitive operating system. Depending on the operating status, illuminated buttons provide a visual indication of the lift's available options regarding direction of movement.

Status	Lift switched off	When switching on the lift	Only lifting possible	Lifting and lowering possible	Only lowering possible	Error, lift not ready for operation
Visual indicator						
Cause		3x flashing → 3.5 t 400 V 50 Hz 4x flashing → 3.5 t 230 V 50 Hz or 3.5 t 230/400 V 60 Hz 5x flashing → 5.5 t / 6.5 t 400 V 50 Hz	<ul style="list-style-type: none"> - start position - obstacle met 	<ul style="list-style-type: none"> - when lifting and lowering 	<ul style="list-style-type: none"> - max. lifting height reached - height limit light barrier reached - Overload/ heavy running 	<ul style="list-style-type: none"> - see section "Troubleshooting Table"

4.3 Preparing the Lifting Operation

4.3.1 Establishing Operational Readiness



MA STAR 3.5 A

MA STAR 3.5 S / 5.5 / 6.5

- The main switch must be at position 0.
- The lift must be lowered all the way down.
- The support arms must be pivoted completely away from the working area (start position, see diagram.).

4.3.2 Positioning the Vehicle

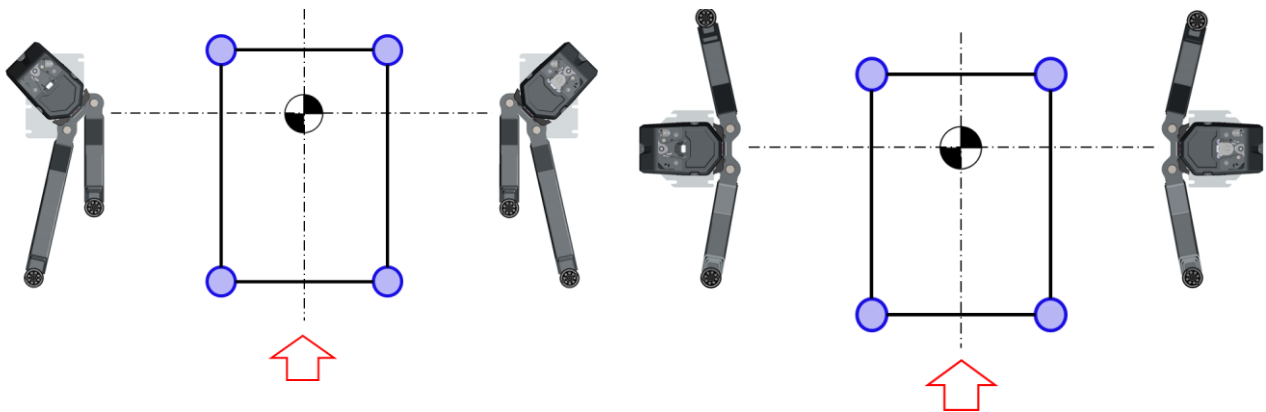

MA STAR 3.5 A

MA STAR 3.5 S / 5.5 / 6.5

- Carefully drive the vehicle forward and centrally between the lifting columns and secure it against rolling away.
- The centre of gravity of the vehicle should be as central as possible between the lift columns.
- Tip: If it is necessary to open the doors completely, the vehicle can also be positioned backwards between the lift columns.
IMPORTANT: Again, ensure that the vehicle's centre of gravity is as central between the two lift columns as possible!

4.3.3 Positioning the Support Arms and Pick-up Plates

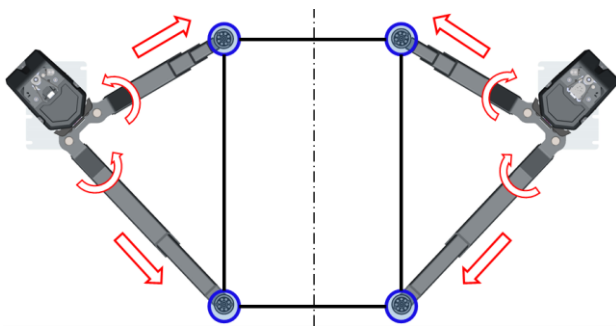

MA STAR 3.5 A

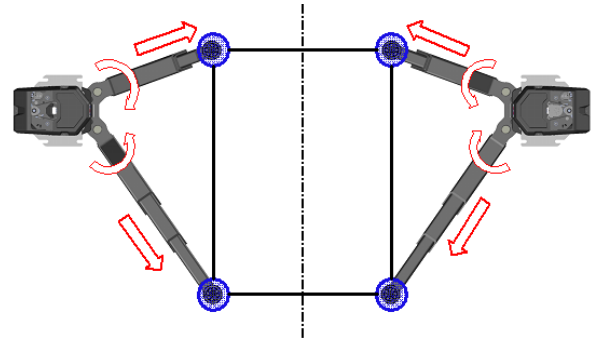

MA STAR 3.5 S / 5.5 / 6.5

- Swivel and extend the support arms to position the support discs under the pick-up points specified by the vehicle manufacturer. The load must rest centrally on the support plates.
- Adjust the height of the support plates so that all four support plates take the load simultaneously and evenly.

4.4 Raising and Lowering Cycles

4.4.1 Inspecting the Load Pick-up Points and Support Arm Locks



WARNING

Never remove the lock pins under full load!



- Set the main switch to position 1. After an initial flashing of all three lights, the UP button is permanently lit.
- Press the UP button until the support discs are in contact with the pick-up points of the vehicle.
- Check the position of the support discs and correct if necessary.
- Check that support arms lock securely. If necessary, move the support arms slightly until the toothed segments are engaged.

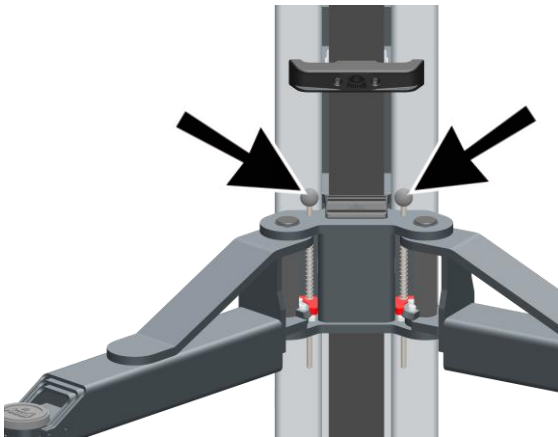

4.4.2 Lashing the Vehicle

The installation / removal of heavy components can lead to unintentional shifts in the vehicle's center of gravity. To prevent the vehicle from falling and causing personal injury, the vehicle must be secured to the support arms, e.g. using lashing straps.

The same applies to the lifting of partially dismantled vehicles, which are to be secured to the vehicle after start-up.

4.4.3 Continuing the Lifting Process



- Continue the lifting process by pressing the UP button until the desired lifting height is reached.
UP and DOWN buttons are lit.

4.4.4 Lowering Process



- Before lowering the vehicle, remove tools, support blocks or similar obstacles from under the vehicle.
The operator is responsible for ensuring that nobody is within the danger zone.
- Press and hold the lit DOWN button until the desired lifting height is reached.
- The lift automatically stops when it has reached the CE-defined stop height.

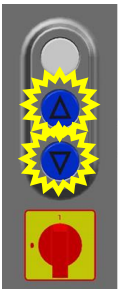

- For full lowering back to the initial position, release the DOWN button after reaching the CE stop and press it again.
- UP and DOWN buttons are lit. A signal sound is activated when lowering within the CE-defined height range.

4.5 Driving the Vehicle off the Lift

- After the lift has been lowered completely, turn the support arms out to the side and bring them back into starting position.
- Switch off the main switch.
- Then drive the vehicle off the lift.

NOTICE

There is a risk of damage to and loss of the toothed segments if the support arms come into contact with the wheels or other vehicle parts!

4.6 Form-Fit Adapters

NOTICE

For the safe lifting of vehicles, it is recommended to use form-fit adapters. Observe the applicable specifications of the vehicle manufacturers.

4.7 Support Disc Raisers



WARNING

- Only **one** raiser may be used per support disc. If support disc raisers are combined, there is a risk of instability and thus a vehicle crash.
 - The anti-rotation lock, which consists of a groove pin and a dowel pin inserted into a sleeve, must always be engaged.
-

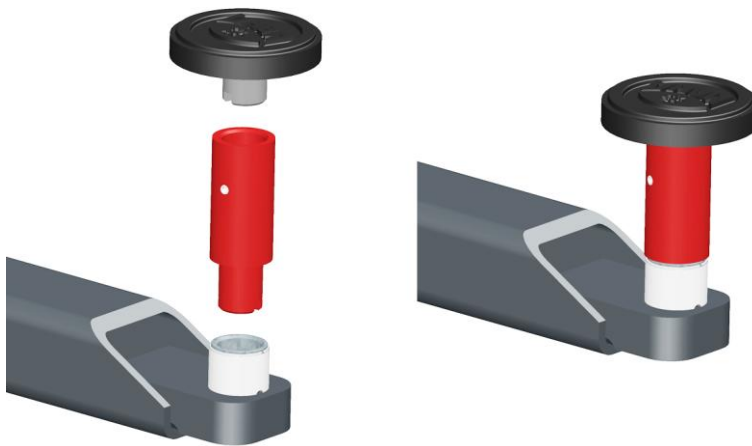

The support disc raisers (partially optional) are available in lengths of 50, 100, 150, 200 and 300 mm.

By inserting the support disc raisers, the support discs can be adjusted in increments of 50 mm. Fine adjustments are possible by turning the support disc.

4.8 Wheel Engaging Supports (MA STAR 5.5 and 6.5 only)

The MA STAR 5.5 and 6.5 can be equipped with wheel engaging supports as an alternative to the disc supports.

The lift is designed according to EN 1493, which specifies a total load capacity and takes into account an asymmetrical load distribution. When using the wheel engaging supports, it should be noted that the vehicle weight with asymmetrical load distribution is no longer decisive, but the individual load-bearing capacity of 1,000 kg per wheel engaging support:

- **Maximum wheel load 1,000 kg**

For the conversion, remove the threaded sleeves and install the wheel engaging supports as shown below.

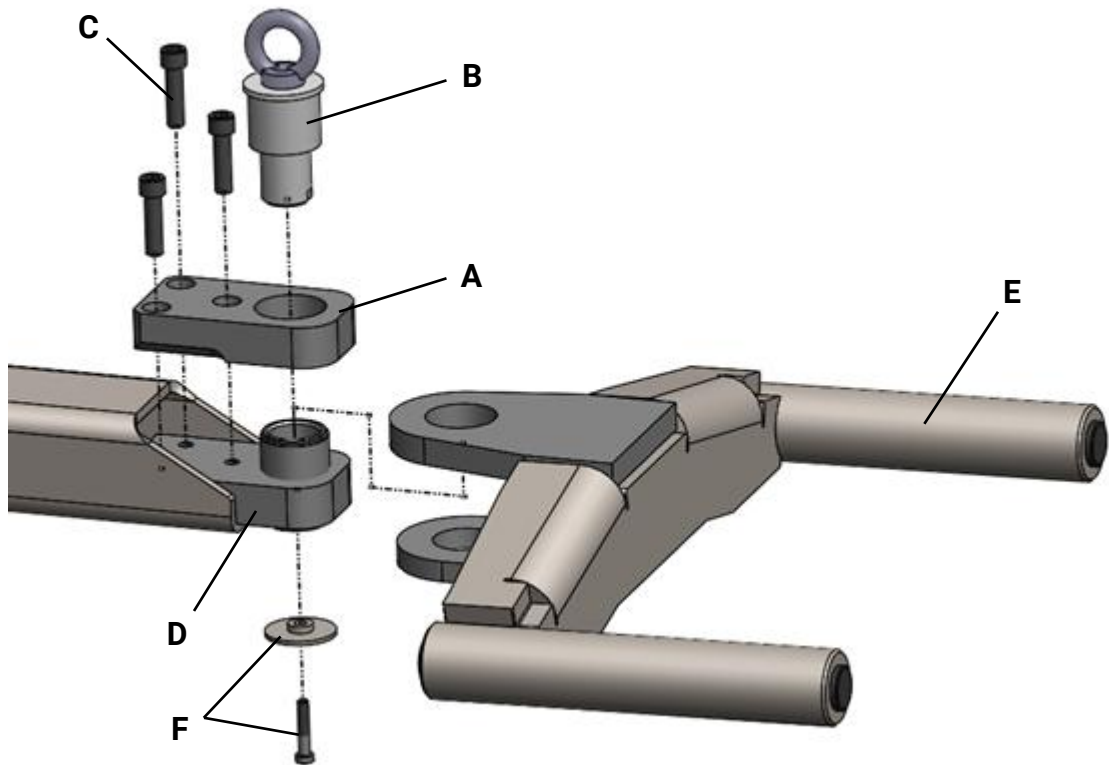

A	Guide plate	D	Threaded sleeve
B	Support pin	E	Wheel engaging fork
C	Fastening screws M12x45 10.9	F	Fastening screw with washer

NOTICE

Lightly grease the sliding surfaces before mounting the wheel engaging supports.

- 1 Screw the support disc all the way down (protruding at the bottom) and remove it.
- 2 Position the guide plate (A) and insert the support pin (B).
- 3 Screw in fastening screws (C) and tighten them hand-tight. Make sure that there is no tension between support pin and guide plate.
- 4 Torque the screws to 120 Nm.
- 5 With the support pin inserted, turn the threaded sleeve (D) upward until it is flush with the guide plate.
- 6 Pull the support pin and fit the wheel engaging fork (E).
- 7 Fully insert the support bolt and turn it down completely.
- 8 Secure the support pin with the fastening screw and washer (F).

4.9 Special Prism Support – Plug-in System



*Special prism support
for MB G-class without tread plate*

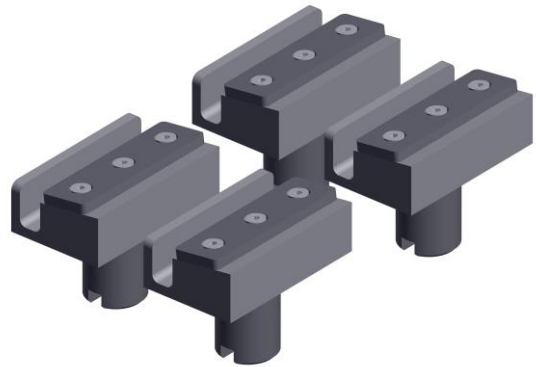

*Special prism support
for MB G-class with tread plate*



WARNING

When using the special prism support with or without a tread plate, the rated load capacity is 3,500 kg.

4.10 Referencing the Control System

NOTICE

To reference the control system, it is recommended to lower the lift completely after every 20 lifting cycles. The unlit DOWN button indicates that the home position has been reached.

5 Troubleshooting

Malfunctions are interruptions in the workflow, such as may occur due to inattention or incorrect operation. Malfunctions can generally be eliminated without tools, except for the disassembly of covers.

When troubleshooting, proceed with caution. The safety instructions for operating the system apply.

5.1 Troubleshooting Table

Display	Diagnostics	Remedy
Signal sound immediately upon switching on.	Button pressed by mistake.	Release button.
	Control panel has short circuit.	Notify service team.
The lift stops when lowering and the blue DOWN button light goes out.	Lift has reached its end position.	Lift can only move upwards. If necessary, the lower end position can be adjusted to ground conditions by the service team.
	Signal sound when DOWN button is pressed again: Lift has met an obstacle.	Free the lift by pressing the UP button, remove the obstacle.
Support arms hit the ground during lowering.	Lower end position has not been set correctly.	Notify service team.
The lift stops when rising and the blue UP button light goes out.	Lift has reached upper end position (max. lifting height).	Lift can only be lowered.
	Signal sound when UP button is pressed again: Ceiling impact protection triggered.	Lower the lift by pressing the DOWN button. Signal tone when key is pressed again only with ceiling light barrier.
	Signal tone sounds immediately after the UP button goes out: Heavy running (max. load exceeded).	Lower the lift by pressing the DOWN button, reduce the load. Signal tone sounds immediately, without pressing the key again. (If necessary, check whether the correct stage mode is configured!)
Signal sound when lowering.	Movement within shearing zone.	No action needed.

Display	Diagnostics	Remedy
Red fault indicator light is permanently on.	Permissible tolerance exceeded.	Notify service team.
	Signal sound when pressing the UP or DOWN button: Support nut breakage.	
Red fault indicator light flashes continuously.	Sensor malfunction.	Notify service team.
	UP and DOWN buttons flash when button is pressed: Wrong stage mode configured.	
DOWN button and UP button and red fault indicator flash more than 10 times.	Configuration mode.	Notify service team.
Red fault indicator flashes, blue DOWN button is lit.	Electrical emergency stop activated.	Lower the lift.
Red fault indicator light and blue UP/DOWN buttons are permanently lit.	Internal fault.	Turn off main switch and switch on again after approx. 5 seconds. Notify service team if the fault reoccurs.

5.2 Emergency Lowering



WARNING

Only for trained personnel! The lift must not be put back into operation until the fault has been eliminated.

5.2.1 Electrical Emergency Lowering



WARNING

The electrical EMERGENCY STOP occurs without monitoring the safety devices! Make sure that the danger zone is clear!

- 1 Keep the DOWN key pressed until the stage moves downwards (approx. 10 s).
- 2 During EMERGENCY AB travel, the indicator lamp flashes red.
- 3 Observe the vehicle during the lowering procedure and stop the lowering movement immediately in case of an inclined position or other hazards!



CAUTION

A second person must be called upon to observe the load!

- 4 Move the lift to home position.

5.2.2 Mechanical Emergency Lowering

- 1 Ensure that the main switch is turned off.
- 2 Remove the covers from both columns.
- 3 Fit the ring wrench/open-end wrench onto the spindle fastening nut:
MA STAR 3.5 AF 36
MA STAR 5.5/6.5 AF 46
- 4 Lower the lifting slide by turning the spindle with the wrench alternately in small steps of approx. 20 mm.



CAUTION

Observe the vehicle during the lowering procedure and stop the lowering movement immediately in the event of an inclined position or other hazards!

6 Inspection Daily before Starting Work

To ensure the safety of the system during operation, the visual and functional checks listed below must be performed daily before starting work or beginning a shift.

6.1 Cables and Actuators

Cables must not show any visible damage. Cables with visible pinch points, damaged sheathing, kinks or bends must be replaced immediately with new ones.

Pushbuttons must be smooth-running and clean and must not show any damage. Actuated pushbuttons must immediately return to their initial position after being released.

A lifting system with damaged cables or actuating elements must not be operated.

6.2 Emergency Stop

The emergency stops (main switch and secondary control panel) stop the drives of the lifting system to bring about a safe state of the system.

For testing, start a lifting movement by pressing the button after switching on the control. With the button pressed, actuate the emergency stop. The movement of the equipment must come to an immediate stop.

The test must be repeated for all control panels with emergency stop. A system with a defective emergency stop must not be put into operation.

6.3 Limitation of the Support Arm Extensions

The lift is equipped with telescopic support arms to accommodate a variety of vehicles. To prevent the vehicle from falling, the support arm telescopes are equipped with limits.

For testing, the support arms must be pulled out by hand. The support arms must not jam when reaching the end position, they must not have excessive play, and it must not be possible to lever them out upwards.

6.4 Function of the Support Arm Lock

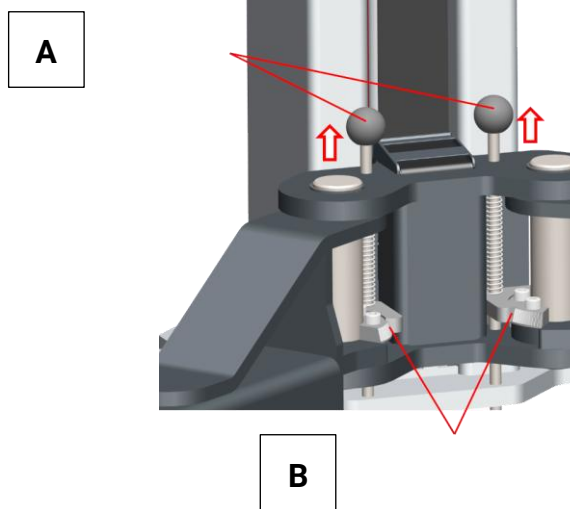

A Locking pin

B Tooth segments

The support arm lock prevents the vehicle from moving horizontally when raised. To this end, toothed segments are attached to the pivot bearing of the support arms, which allow free movement of the support arms in the lower end position and automatically engage with each other when lifted.

For inspection, check the locking bolt for free movement and the tooth segments for correct engagement daily before starting work. The tooth segments are correctly fixed when all teeth are fully engaged. If necessary, clean the tooth segments with a steel brush and lightly grease the tooth flanks.

The locking bolts must move easily and must not be damaged (bent).

Support arm locks that do not have the engagement described above, that have broken teeth, or that are otherwise damaged, must be replaced immediately in pairs with new segments. The same applies to damaged locking bolts.

6.5 Load Supports

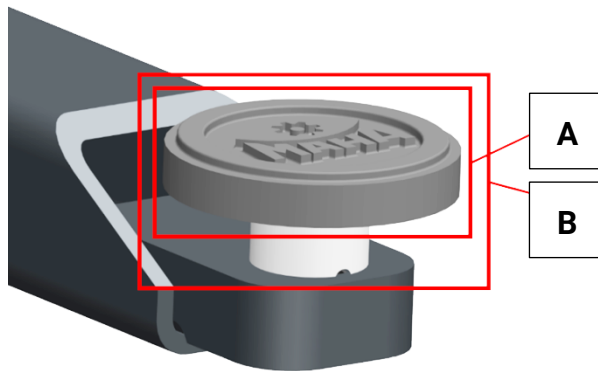

A Rubber pad

B Support plate with thread

Support plates take over the load and hold this in position. The rubber pad yields selectively under load. This protects the vehicle's mounting point and prevents the vehicle from slipping. If the rubber pad is damaged, this function can no longer be performed safely. Slipping of the vehicle and a vehicle crash is possible.

Support plates must not have any cracks or chipping. Defective support plates must be replaced.

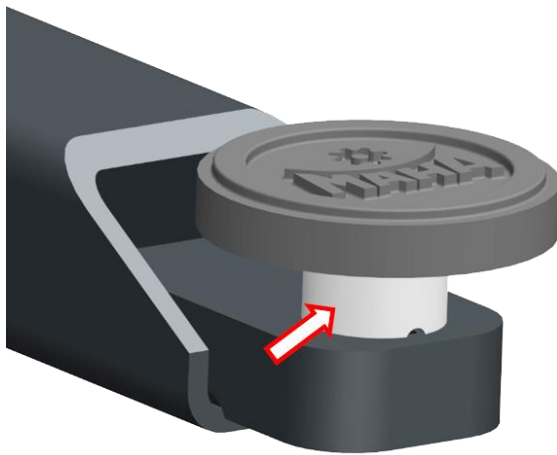

The thread on the support plate is used for height adjustment so that the vehicle rests evenly on all four support plates during lifting. This thread must be smooth-running. Dirty thread should be cleaned and lightly greased.

The circlip on the bottom must be present and correctly mounted.

7 Servicing by the Operator

7.1 Safety Instructions



WARNING

- The relevant health and safety regulations must be observed.
- Wear personal protective equipment.
- Repairs, maintenance and set-up work should only be carried out when the machinery is stationary and unloaded. The unit must be disconnected from the power supply and secured against being switched on again.
- Only use original replacement parts.
- Substances that are hazardous to the environment must be disposed of appropriately.
- Do not use high or steam pressure equipment or harsh cleaning agents to clean the lift.

7.2 Lubrication

7.2.1 Lubrication Points and Lubricants

NOTICE

Only the following lubricants are permitted for servicing and maintaining the lift!

Lubrication points	Lubricants
Spindle/support nut	Gear oil of viscosity class SAE 140 (Art. No. 1402567) IMPORTANT: Safe and fault-free operation cannot be guaranteed if other lubricants are used!
Sliding block tracks	FUCHS LUBRITECH STABYL TA (Art.-No. 1405686) IMPORTANT: The service life of the sliding blocks may be reduced if other lubricants are used!
Support arm extensions Thread of the support plates	Suitable penetrating oil or spray oil (such as WD 40, Interflon, etc.)
Support arm lock Spindle bearing (MA STAR 5.5/6.5)	Multipurpose grease

7.2.2 Lubricating the Spindle and the Load Nut

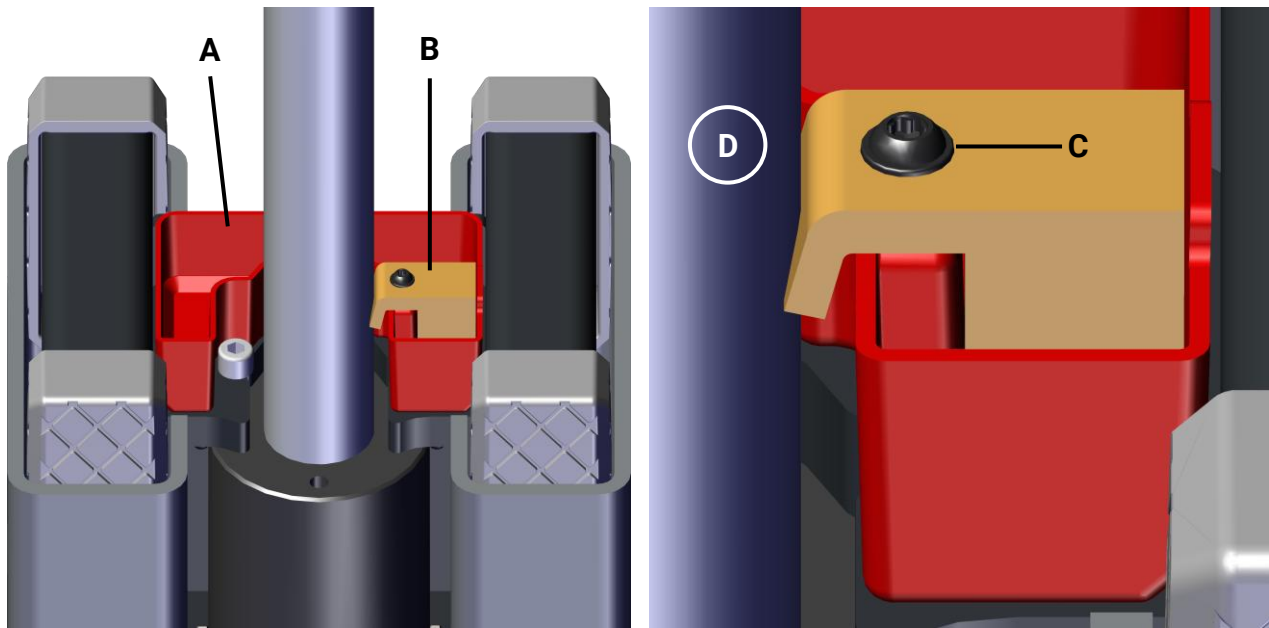

A Oil pan

B Lubrication felt

C Torx screw

D Spindle

NOTICE

If there is dirt in the oil pan, this can impair the running characteristics of the lift!

The oil pan in the lifting carriage must always be filled so that there is a permanent lubricating film on the spindle and thermal load is avoided. Refill the oil pan or more often if necessary.

Also check the lubrication felt for wear and/or contamination and replace at least every 12 months. The lubrication felt must be positioned at the spindle with its edge facing downward (see illustration).

7.2.3 Greasing the Slide Tracks

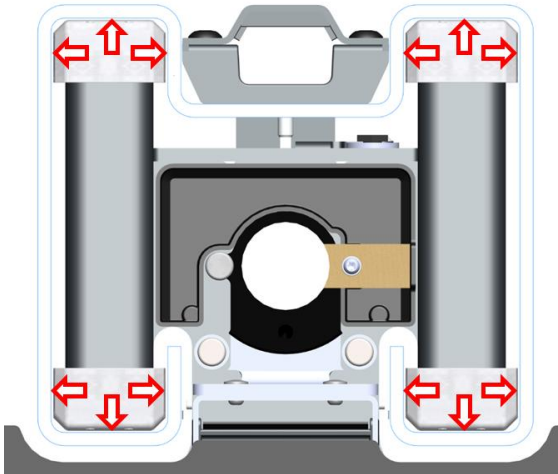

Lubricate the raceways of the sliding blocks at least every 6 months. To do so, move the lifting carriage to the lowest position. Then loosen and remove the spindle cover on the head plate. Lightly grease all slider tracks over the entire length with a brush.

7.2.4 Greasing the Arm Extensions

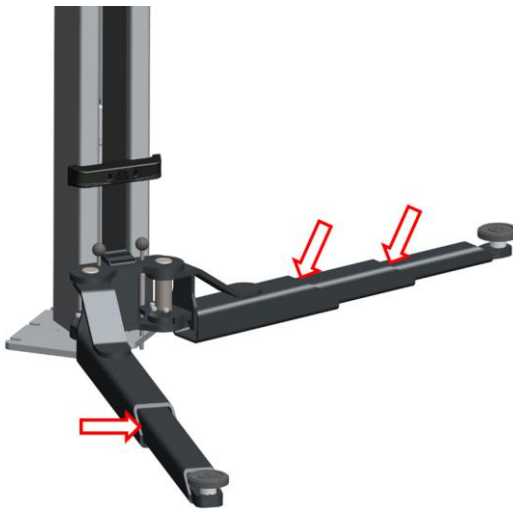

Check the support arms for free movement at least every 6 months and lightly oil the pull-out points and the roller support if necessary.

7.2.5 Lubricating the Thread of the Support Discs

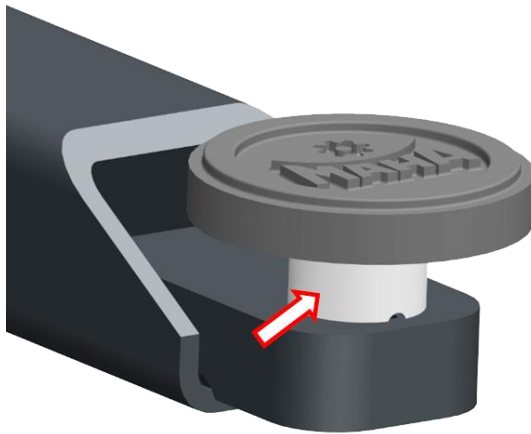

Check the threads of the support discs for free movement at least every 6 months and lightly oil if necessary.

7.2.6 Lubricating the Spindle Bearing (MA STAR 5.5 / 6.5 only)



Lubricate the upper spindle bearing at least once a year. Lower the lifting carriage to bottom position; loosen the spindle cover at the head plate and remove it. Then lubricate the spindle bearing with multipurpose grease through the lubrication nipple.

7.3 Checking the Load Nut's Wear Indicator

The load nut's wear indicator must be checked every 6 months, and the pair of nuts must be replaced when the wear limit is reached. If this condition is ignored, the load nut may break through as wear progresses. In this case, the downstream safety nut takes over the load completely and the vehicle can be lowered, but it cannot be raised again from the home position.

The following dimensions must be observed:

	MA STAR 3.5	MA STAR 5.5 / 6.5
New condition	Cylinder head screw M8x45 (A) rests against support plate (B) of lifting carriage.	Upper edge of M8x40 threaded pin (C) is flush with upper edge of support plate (B).
Wear limit	Gap between cylinder head screw and support plate is ≥ 2 mm.	Threaded pin protrudes ≥ 3 mm above support plate. <i>Alternatively:</i> Upper edge of threaded pin is flush with upper edge of oil pan holder (D) or higher.

MA STAR 3.5

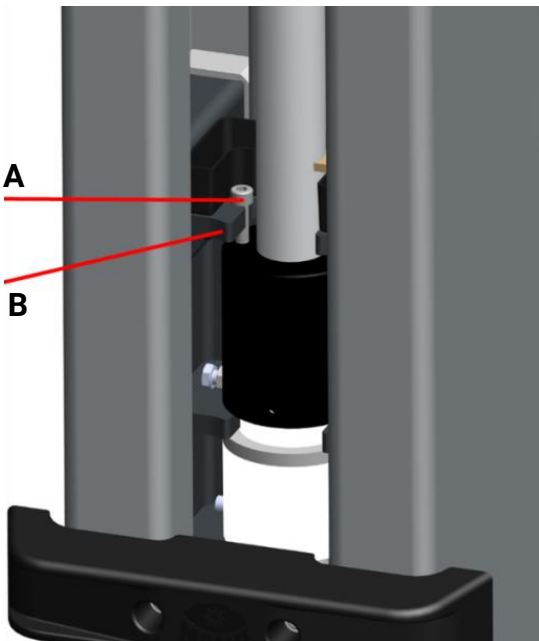

A Cylinder head screw M8x45

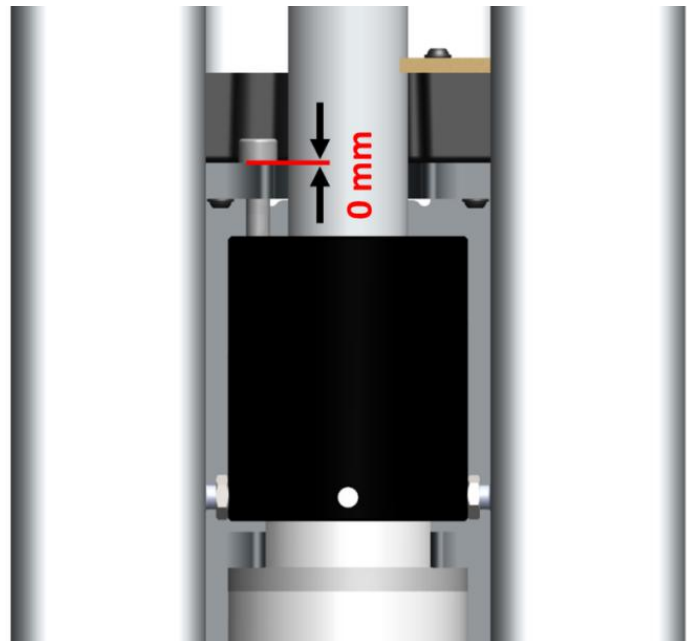

B Support plate

MA STAR 5.5 / 6.5

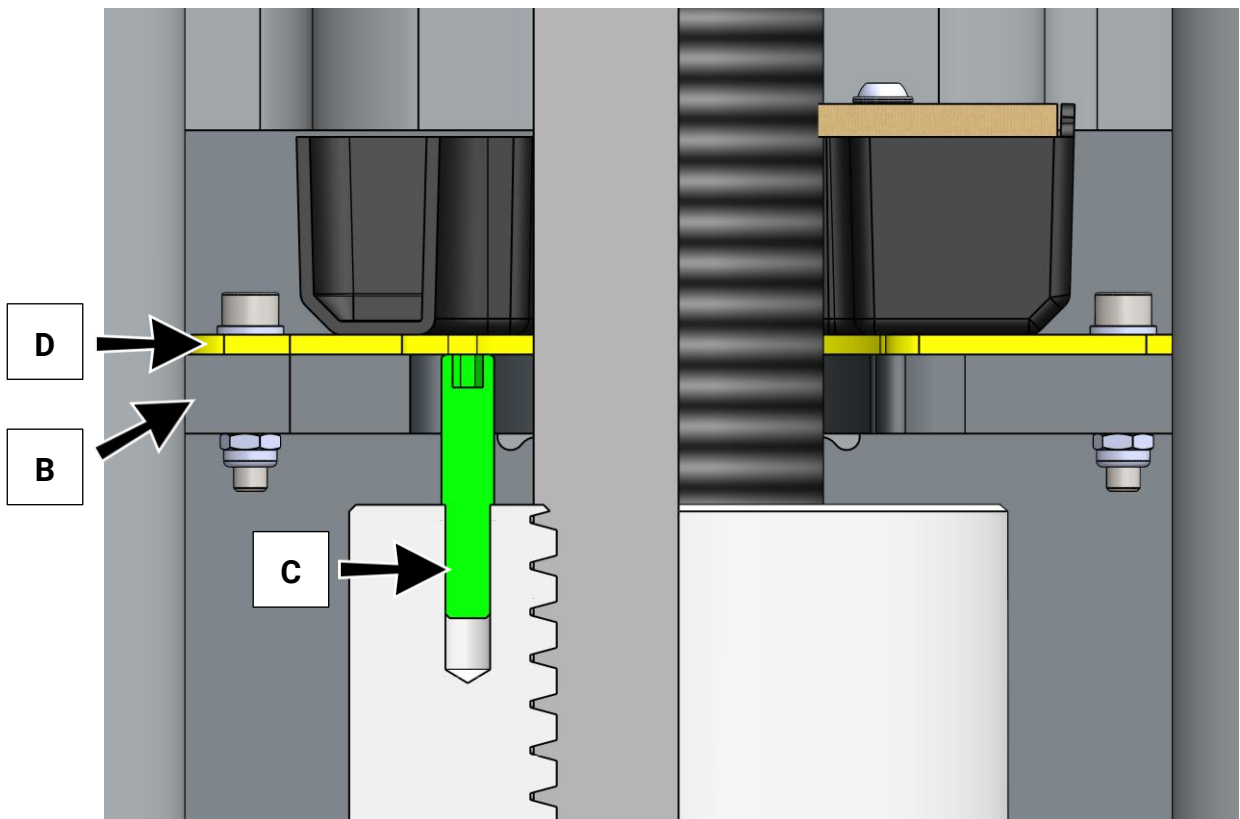
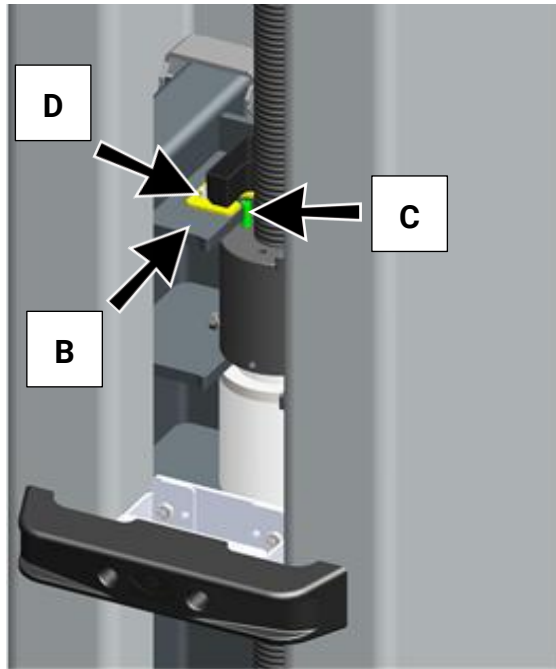

B Support plate

C Threaded pin M8x40

D Oil pan holder (thickness 3 mm)

8 Extended Warranty

MAHA grants the operator of the lift a warranty on the functionality of the spindle drive beyond the statutory warranty period. This warranty covers wear of the support nut, if it exceeds 2 mm, and wear on the lifting screw, if it restricts / hinders / prevents the operation of the lift.

This warranty is limited to the replacement of the worn component(s). It is valid for a maximum of five years after initial start-up and only if the regular inspection and maintenance intervals according to these operating instructions have been demonstrably observed. Compliance is only deemed to have been demonstrated if the required work has been carried out by our factory customer service, one of our dealers or one of our service partners.

The extended warranty does not apply if the equipment has not been operated - even temporarily - in accordance with its intended use.

9 Decommissioning, Dismantling and Disposal

The device may only be taken out of operation and disassembled by specially authorised and trained personnel. Such specialist staff include authorised, trained specialists employed by the manufacturer, the authorised dealers and the relevant service partners.

Observe the product and safety data sheets of the lubricants used. Avoid environmental damage. If the device is to be disposed of, it must be disposed of in an environmentally responsible manner in accordance with local legislation. Sort all dismantled materials according to type and take them to a suitable recycling point. Collect operating materials such as grease, oil, coolant, cleaning fluids containing solvents etc. in suitable containers and dispose of them in an environmentally responsible manner.

Alternatively, you can take your device to a waste management company. They will ensure that all parts and fluids are disposed of properly and ecologically.

10 Declaration of Conformity

See following page(s).



**Original-EG-Konformitätserklärung
Original EC Declaration of Conformity**

CE364501-de-en



MAHA SE & Co. KG

erklärt hiermit als Hersteller in alleiniger Verantwortung, dass nachstehend bezeichnetes Produkt in Konzeption und Bauart den grundlegenden Sicherheits- und Gesundheitsanforderungen der hier genannten Richtlinien entspricht.

Bei Änderungen am Produkt, die nicht von oben genannter Firma genehmigt wurden, verliert diese Erklärung ihre Gültigkeit.

herewith declares as a manufacturer its sole responsibility to ensure that the product named hereafter meets the safety and health regulations both in design and construction required by the directives stated below.

This declaration becomes void if any change is made to the product that was not approved by named company beforehand.

Typ | Model

MA STAR 3.5 A STOCK..... VP 251230
MA STAR 3.5 S STOCK..... VP 251231
MA STAR 3.5 A..... VP 251232
MA STAR 3.5 S..... VP 251233
MA STAR 3.5 A BMW VP 251234
MA STAR 3.5 A MB..... VP 251235
VAS 771 043 (MA STAR 3.5 A)..... VP 251236

MA STAR 5.5 STOCK..... VP 451186
MA STAR 5.5..... VP 451187
MA STAR 5.5 MB..... VP 451188
VAS 771 045 (MA STAR 5.5)..... VP 451192

MA STAR 6.5 STOCK..... VP 451189
MA STAR 6.5..... VP 451190
MA STAR 6.5 MB..... VP 451194

Serialnummer | Serial Number

Bezeichnung | Designation

Zwei-Säulen-Hebebühne

Two Post Lift

Richtlinien | Directives

2006/42/EG
2014/53/EU

2006/42/EC
2014/53/EU

Normen | Standards

EN 1493:2022
EN 60204-1:2018
EN ISO 13849-1:2023

Bevollmächtigter für die Zusammenstellung der technischen Unterlagen

Person Authorised to Compile the Technical File

Ralf Kerkmeier • MAHA SE & Co. KG • Hoyen 20 • 87490 Haldenwang • Germany

Haldenwang, 2025-11-17

Dr. Peter Geigle
Geschäftsführer | Managing Director

