



MAHAGROUP

# AL II

Axle Jack

Original Operating Instructions

BA082201-en

AL II 2.0  
AL II 2.0 PH

AL II 2.6  
AL II 2.6 PH  
AL II 2.6 PH W  
AL II 2.6 PH S

AL II 4.0 PH W

© MAHA Maschinenbau Haldenwang GmbH & Co. KG

The reproduction, distribution and utilisation of this document as well as the communication of its contents to others without explicit authorisation is prohibited. Offenders will be held liable for the payment of damages. All rights reserved in the event of the grant of a patent, utility model or design.

The contents have been checked with great care; however, errors cannot be fully excluded. Illustrations are examples and may differ from the original product. Subject to technical change without notice.

**Manufacturer**

MAHA Maschinenbau Haldenwang GmbH & Co. KG  
Hoyen 20  
87490 Haldenwang  
Germany

Phone: +49 8374 585-0  
Fax: +49 8374 585-590  
Mail: maha@maha.de  
Web: www.maha.de

**Service**

MAHA SERVICE CENTER  
Maybachstraße 8  
87437 Kempten  
Germany

Phone: +49 8374 585-100  
Fax: +49 8374 585-491  
Mail: service@maha.de  
Web: www.mahaservicecenter.de

**Contents**

1	Safety.....	4
1.1	Introduction.....	4
1.2	Symbols and Signal Words .....	4
1.2.1	Personal Injury.....	4
1.2.2	Property Damage .....	4
1.2.3	Information.....	4
1.3	Intended Use .....	5
1.4	Inappropriate Use .....	5
1.5	Requirements on Operating and Service Personnel .....	5
1.6	Safety Instructions for Commissioning.....	6
1.7	Safety Instructions for Operation .....	6
1.8	Safety Instructions for Servicing.....	7
1.9	Safety Instructions for Handling Hydraulic Fluid .....	7
1.10	What to Do in the Event of an Accident.....	7
2	Transport and Storage.....	8
3	Installation and Initial Operation .....	8
4	Technical Data .....	9
5	Installation Position .....	10
6	Installation Options.....	10
6.1	Installing the Withdrawal Protection Device .....	11
6.1.1	Two Post Inground Lifts .....	11
6.1.2	Four Post Inground Lifts .....	11
6.1.3	CARLIFT .....	12
6.1.4	DUO .....	12
6.2	Installing the Spiral Hose .....	14
6.2.1	Two Post Inground Lifts .....	14

6.2.2	Four Post Inground Lifts .....	15
6.2.3	CARLIFT .....	16
6.2.4	DUO .....	17
6.3	Park Position .....	18
6.3.1	Two Post Inground Lifts .....	18
6.3.2	Four Post Inground Lifts .....	19
6.3.3	DUO .....	20
7	Installation Procedure.....	23
8	Operation .....	25
8.1	Operation of AL II 2.0 / 2.6.....	25
8.2	Operation of AL II 2.0 PH / 2.6 PH / 4.0 PH .....	25
8.3	Operation of AL II 2.6 PH W / 2.6 PH S .....	26
8.4	After Usage .....	26
9	Maintenance.....	27
9.1	Maintenance Schedule .....	27
9.2	Annual Inspection .....	28
9.3	Care Instructions .....	28
9.4	Refilling with Hydraulic Fluid.....	29
9.5	Troubleshooting.....	29
9.6	Spare Parts.....	29
9.7	Hydraulic Diagram .....	30
10	Service Lifetime .....	31
11	Dismantling .....	31
12	Disposal .....	31
13	Contents of the Declaration of Conformity .....	31

# 1 Safety

## 1.1 Introduction

Thoroughly read this manual before operating the equipment and comply with the instructions. Always display the manual in a conspicuous location.

Personal injury and property damage incurred due to non-compliance with these safety instructions are not covered by the product liability regulations.

## 1.2 Symbols and Signal Words

### 1.2.1 Personal Injury



#### **DANGER**

indicates an immediate hazard which, if not avoided, will result in death or severe personal injury.

---



#### **WARNING**

indicates a potential hazard which, if not avoided, could result in death or severe personal injury.

---



#### **CAUTION**

indicates a potential hazard which, if not avoided, could result in moderate or minor personal injury.

---

### 1.2.2 Property Damage

#### **NOTICE**

indicates a potentially harmful situation which, if not avoided, could result in damage to the equipment or surrounding objects.

---

### 1.2.3 Information



indicates important information notes.

---

### 1.3 Intended Use

- This axle jack is to be used exclusively for the safe lifting of motor vehicles. Observe the rated load capacity.
- The axle jack shall not be modified without the express written consent of the manufacturer. In case of non-compliance the declaration of conformity becomes void.

### 1.4 Inappropriate Use



#### WARNING

Any use other than described is inappropriate, for example:

- Climbing on the lift supports
  - Transporting persons on the lift supports
  - Usage as mobile work platform or for other lifting operations
- 

### 1.5 Requirements on Operating and Service Personnel



#### WARNING

All persons employed in the operation, maintenance, installation, removal and disposal of the device must

- be at least 18 years old,
  - be mentally and physically suited for these activities,
  - be demonstrably trained and instructed in writing,
  - have read and understood the operating instructions, especially the instructions what to do in the event of defects or malfunctions,
  - be on record as having been instructed in safety guidelines,
  - have practical experience in working with vehicle lifts and the hazards inherent in such equipment.
-

## 1.6 Safety Instructions for Commissioning



### WARNING

- The axle jack must be installed and commissioned by authorized service personnel only.
  - The axle jack must be installed only with a suitable running gear on level, stable and parallel guide rails or working pits. It must be secured against falling out and derailment.
  - The standard axle jack version must not be installed and commissioned in the vicinity of explosives or flammable liquids, outdoors or in moist rooms (e.g. car wash).
- 

## 1.7 Safety Instructions for Operation



### WARNING

- Read the detailed operating instructions.
  - Lift operation by trained personnel over 18 years only.
  - The load capacity of the axle jack must not exceed 2/3 of the lift load capacity.
  - Ensure an unobstructed movement of the axle jack.
  - After raising the vehicle briefly, stop and check the supports for secure contact.
  - Make sure the vehicle doors are closed during raising and lowering cycles.
  - Closely watch axle jack and vehicle during raising and lowering cycles.
  - Before each lifting procedure, check whether the running gear of the axle jack is correctly placed.
  - It is the operator's responsibility to make sure that operation represents no danger to persons.
  - The axle jack is to be used as lifting device only. Never transport the load using the axle jack.
  - Before working on the vehicle, lower the axle jack to nearest safety notch.
  - When lifting a vehicle with two axle jack units, they must have a minimum separation of 0.85 m.
  - Do not allow anyone to stay in lift area during raising and lowering cycles.
  - Do not allow anyone to climb on the raised vehicle.
  - Comply with the applicable accident prevention regulations.
  - Do not exceed the rated load capacity as indicated on the type nameplate.
  - Only use the vehicle manufacturer's recommended lift points.
  - Do not use the lift for transporting persons.
  - Keep the axle jack and the working area clean.
-

- Use caution with operating vehicle engines. Danger of poisoning!
- 

## 1.8 Safety Instructions for Servicing



### WARNING

- Service work may be done by authorized service technicians only.
  - Ensure that ecologically harmful substances are disposed of only in accordance with the appropriate regulations.
  - Do not use high pressure or steam jet cleaners.
  - Use of caustic cleaning agents may damage the axle jack.
  - Do not replace or override the lift safety devices.
- 

## 1.9 Safety Instructions for Handling Hydraulic Fluid



### CAUTION

- Neutralise hydraulic fluid spills with binder.
  - Remove contaminated clothing immediately.
  - Inhalation: If symptoms persist, seek medical treatment.
  - Skin contact: Wash skin immediately with soap and water. If skin irritation persists, seek immediate medical advice.
  - Eye contact: Rinse thoroughly with water and seek medical advice.
  - Ingestion: Do not induce vomiting. Seek immediate medical attention.
- 

## 1.10 What to Do in the Event of an Accident

- The injured person is to be removed from the danger area. Find out where dressing and bandages are kept. Seek first-aid.
- Provide first-aid (stop bleeding, immobilise injured limbs), report the accident and seal off the accident site.
- Immediately report any accident to your supervisor. Make sure a record is kept of every occasion first-aid is provided, e.g. in an accident book.
- Remain calm and answer any questions that may arise.

## 2 Transport and Storage

### NOTICE

Check package to ensure it is complete, in accordance with the order confirmation. Report any transport damage to the carrier immediately.

During loading, unloading and transport always use suitable lifting equipment, material handling equipment (e.g. cranes, forklifts, etc.) and the right load handling attachments and slings. Always ensure that the parts to be transported are suspended or loaded properly so that they cannot fall, taking into account size, weight and the centre of gravity.

Store the packages in a covered area, protected from direct sunlight, at a low humidity and with temperatures between 0...+40 °C (32...104 °F). Do not stack packages.

When unpacking, take care to avoid any possibility of injury or damage. Keep at a safe distance when opening the package strapping, do not allow any parts to fall out.

---

## 3 Installation and Initial Operation



### WARNING

Installation and initial operation of the equipment may be done only by authorized and trained service technicians provided by the manufacturer, licensed dealers or service partners.

---



## 4 Technical Data

AL II	2.0	2.0 PH
Extension length min...max.	780...1610 mm	780...1610 mm
Working pressure min...max.	---	8.5...12 bar
Full travel	250 mm	250 mm
Minimum air flow	---	500 l/min
Load capacity	2000 kg	2000 kg
Protrusion above runway max.	70 mm	70 mm

AL II	2.6	2.6 PH
Extension length min...max.	780...1610 mm	780...1610 mm
Working pressure min...max.	---	8,5...12 bar
Full travel	250 mm	250 mm
Minimum air flow	---	500 l/min
Load capacity	2600 kg	2600 kg
Protrusion above runway max.	70 mm	70 mm

AL II	2.6 PH W	2.6 PH S	4.0 PH
Extension length min...max.	780...1865 mm	780...1610 mm	796 1650 mm
Working pressure min...max.	8.5...12 bar	8.5...12 bar	8.5...12 bar
Full travel	250 mm	250 mm	250 mm
Minimum air flow	500 l/min	500 l/min	500 l/min
Load capacity	2600 kg	2600 kg	4000 kg
Protrusion above runway max.	80 mm	70 mm	70 mm

The sound pressure level is lower than 85 dB(A) in the working area of the operator.

## 5 Installation Position

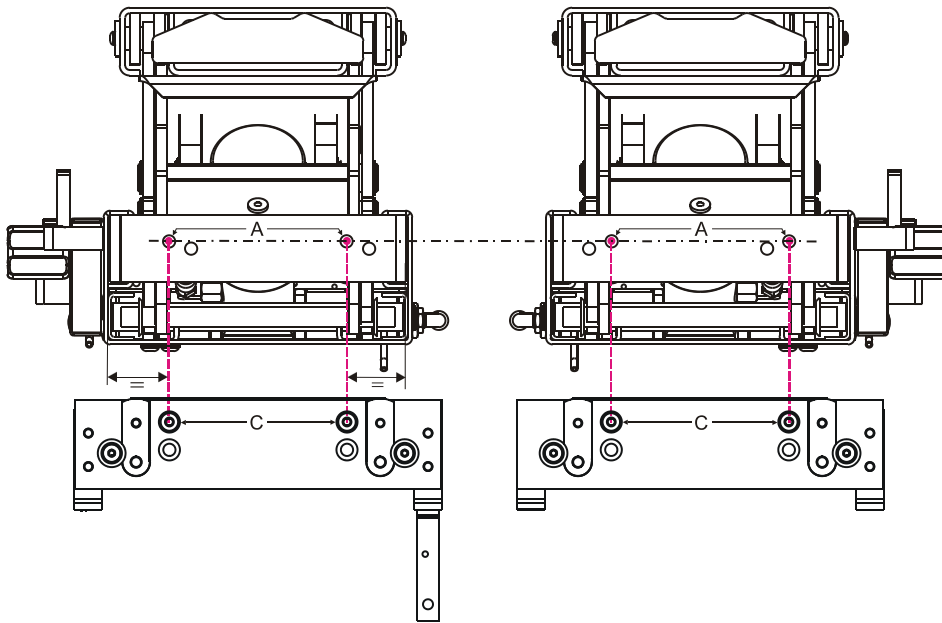

- A Drill holes in side part of Axle jack, centered in longitudinal direction
- C Drill holes in side part of Lift, top

## 6 Installation Options



When the axle lift is in park position, the spiral hose must be contracted in order to be strain-relieved.

- Inground Two/Four Post Lifts .....Variant A
- DUO.....Variant A
- CARLIFT .....Variant A, if required: Variant B

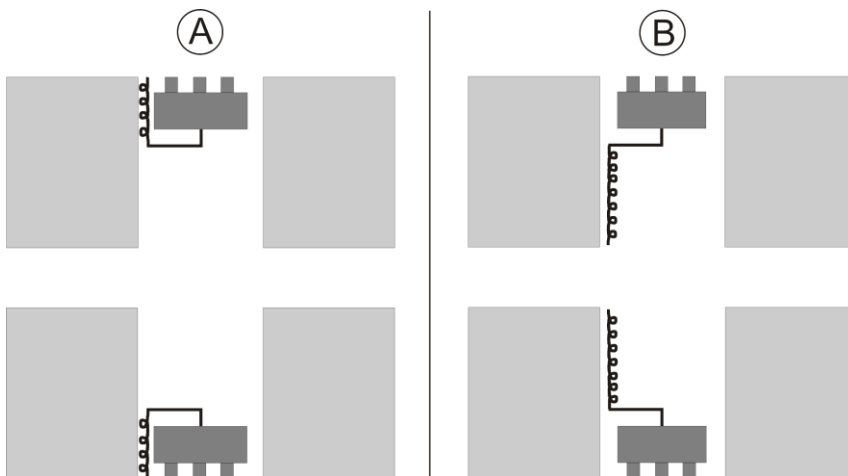

## 6.1 Installing the Withdrawal Protection Device



### CAUTION

#### Risk of personal injury and property damage

The installation of the withdrawal protection devices is absolutely necessary. Otherwise the axle jack may fall out of the running rail.

---

### 6.1.1 Two Post Inground Lifts

- Install the withdrawal protection device (A) and the hose fixture (B).

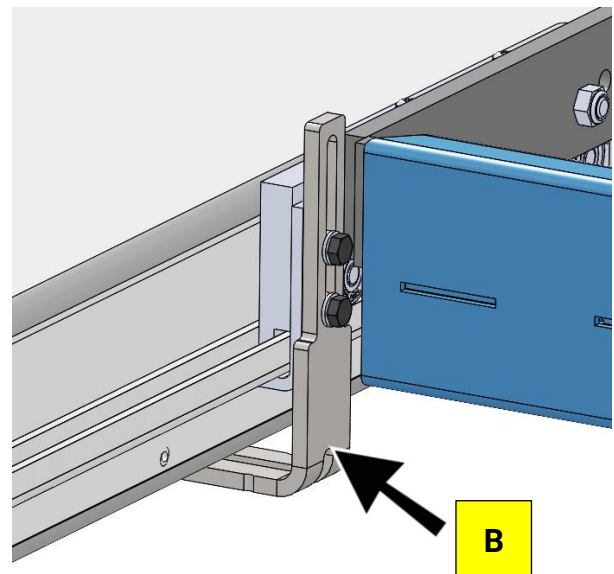
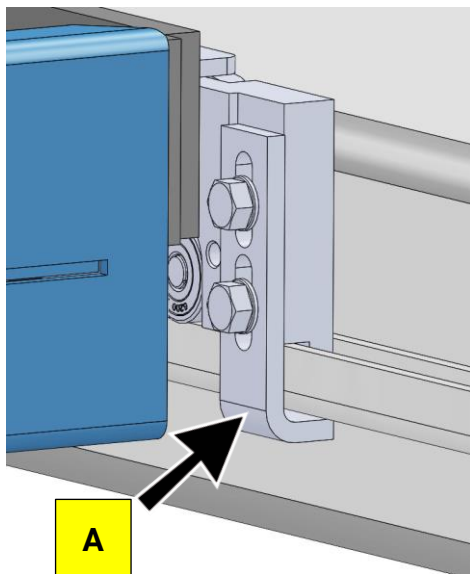

### 6.1.2 Four Post Inground Lifts

- Install the withdrawal protection device (A) and the hose fixture (B).

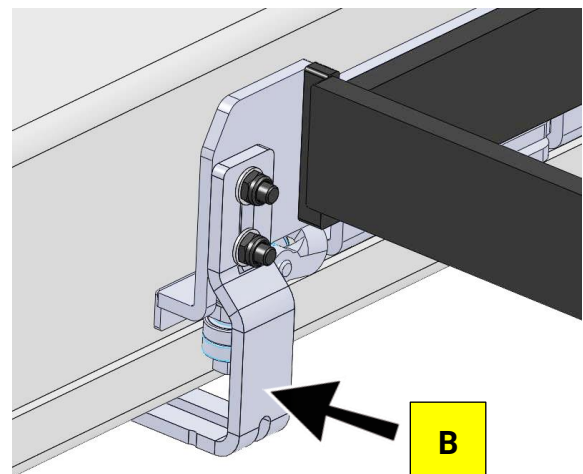
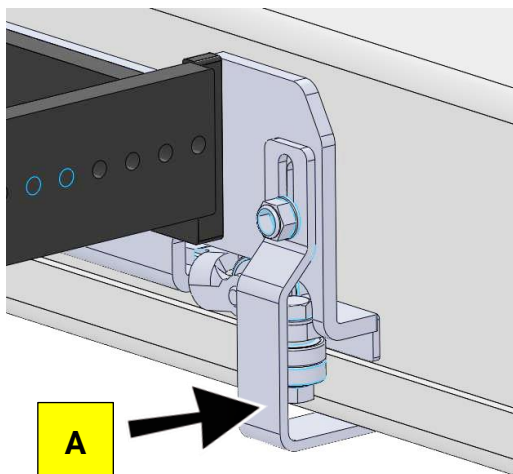

### 6.1.3 CARLIFT

- Install the withdrawal protection devices (four angles per axle jack) as shown.

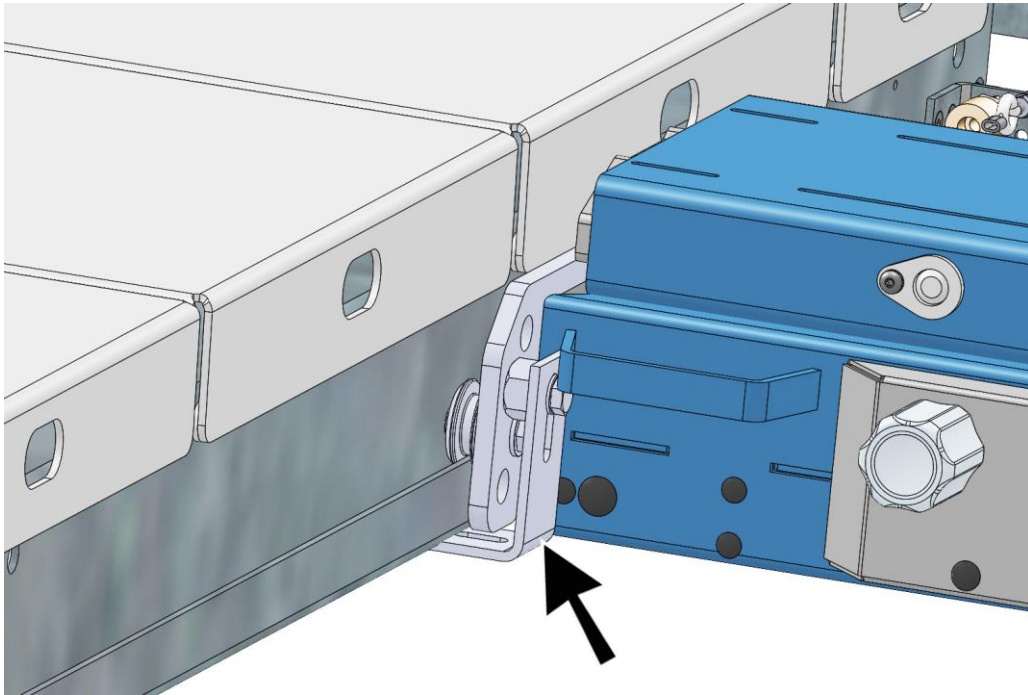

### 6.1.4 DUO

- Install the withdrawal protection device (A) and the hose fixture (B).

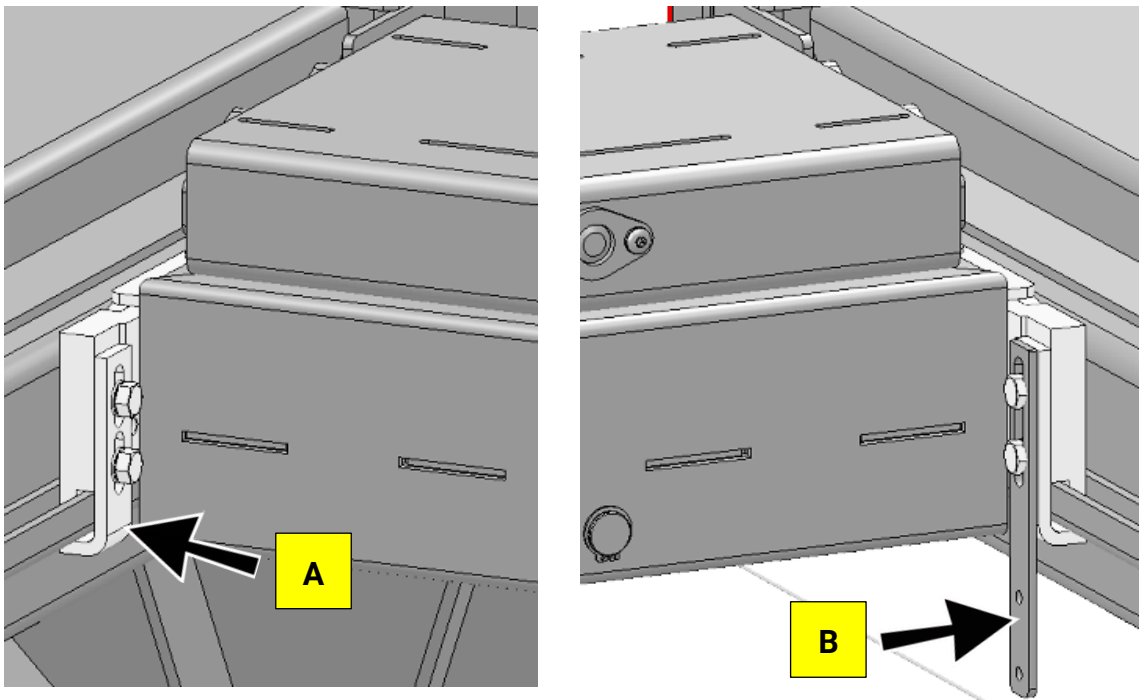

## DUO 5.0 with Recessed Wheel-Free Jack

With this configuration, an adaption must be made to avoid collisions between the side part of the axle jack and the extensions of the wheel-free jack. For this purpose, sliding strips (see Fig. below) are affixed to the side part and the withdrawal protection device to securely guide the axle jack in its rail.

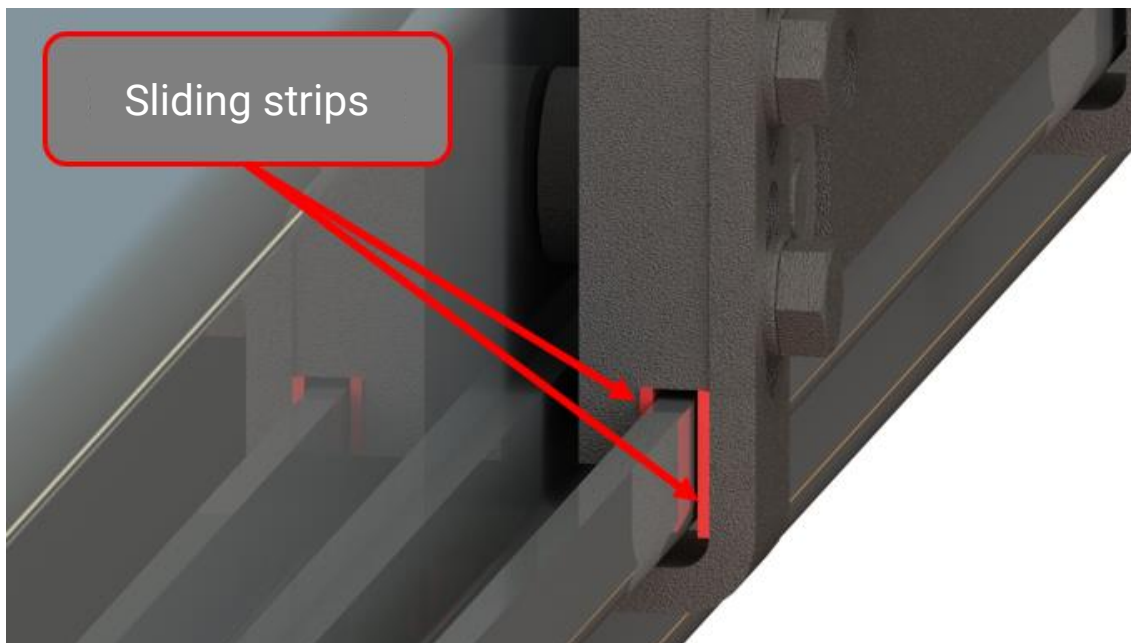

- Cut the sliding strips (art. no. 23003131) to size and affix them to the side part and the withdrawal protection device.

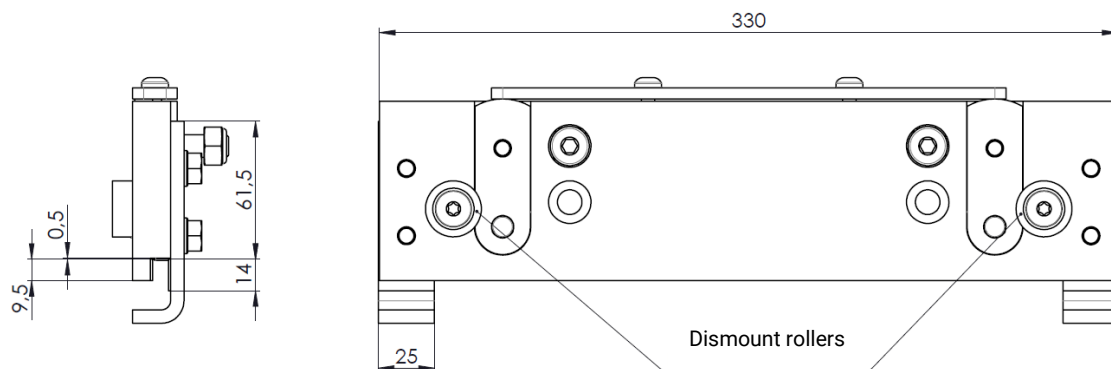

- Then dismount the rollers which were previously used for guiding the axle jack.

### NOTICE

To prevent the axle jack from jamming while being moved, make sure the runways are installed sufficiently parallel.

## 6.2 Installing the Spiral Hose

### NOTICE

#### Risk of property damage

Make sure that the spiral hose is installed without kinks.

---

### 6.2.1 Two Post Inground Lifts

- Slide the spiral hose (A) over the wire rope (B).
- Tension the wire rope using the ring bolt (C).
- Fasten the hose end to the hose fixture using cable ties.

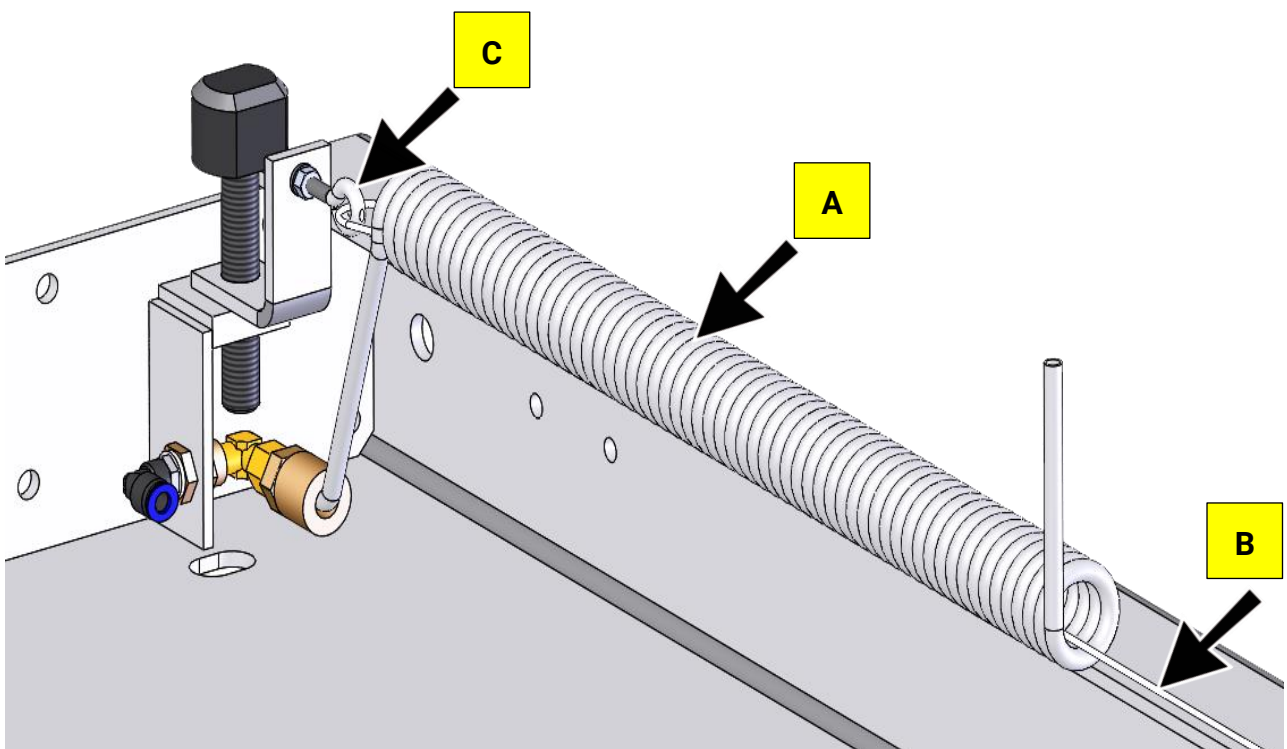

(Bottom view of runway)

## 6.2.2 Four Post Inground Lifts

- Slide the spiral hose (A) over the wire rope (B).
- Tension the wire rope using the ring bolt (C).
- Fasten the hose end to the hose fixture using cable ties.

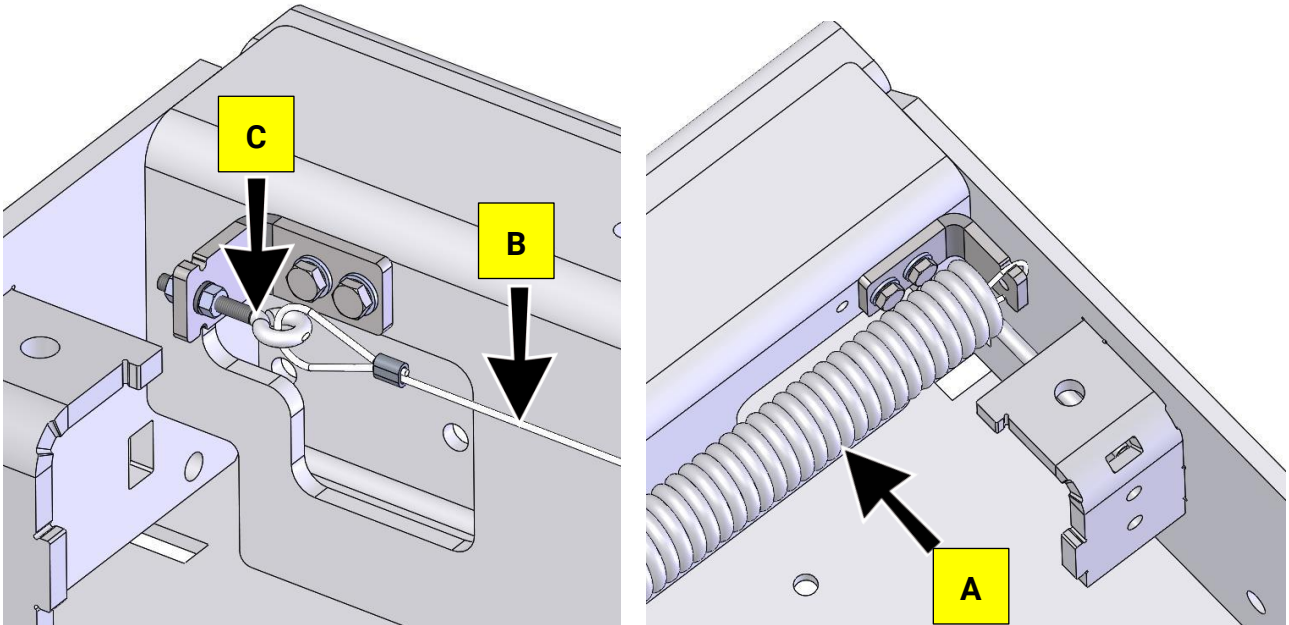

(Bottom view of runway)



### 6.2.3 CARLIFT

- Slide the spiral hose (A) over the wire rope (B).
- Tension the wire rope using the ring bolt (C).
- Fasten the hose end to the hose fixture using cable ties.

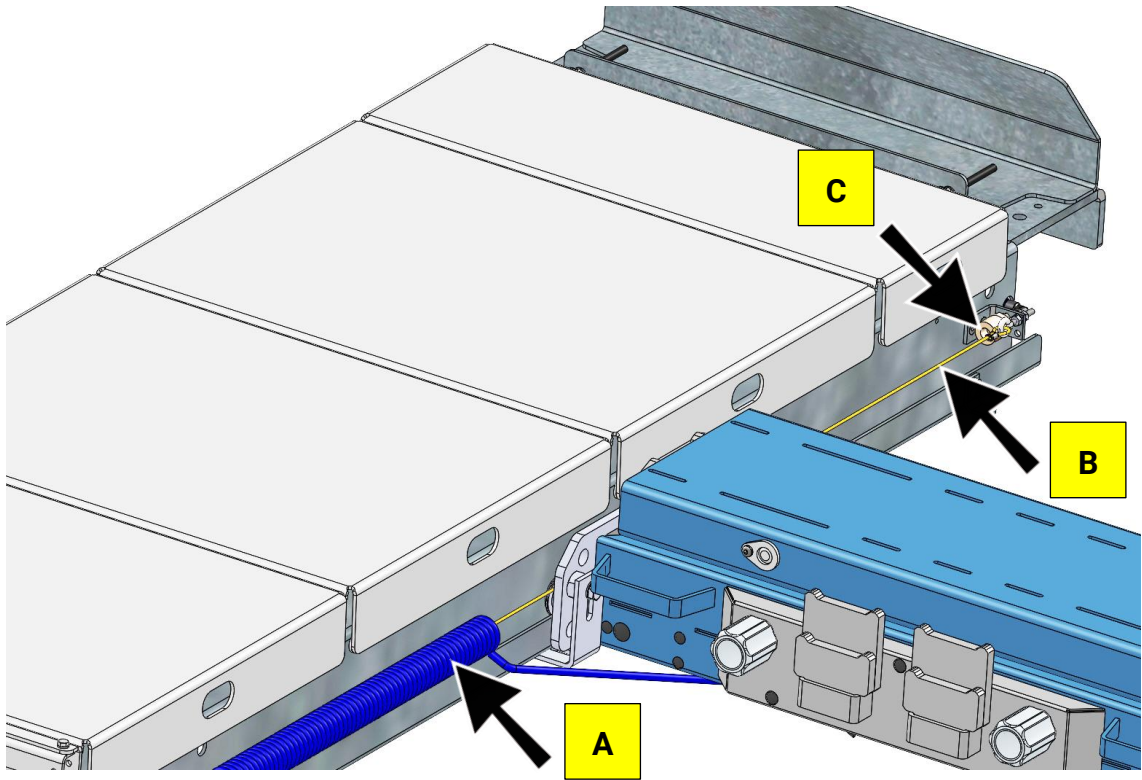



## 6.2.4 DUO

- Slide the spiral hose (A) over the wire rope (B).
- Tension the wire rope using the ring bolt (C).
- Fasten the hose end to the hose fixture using cable ties.

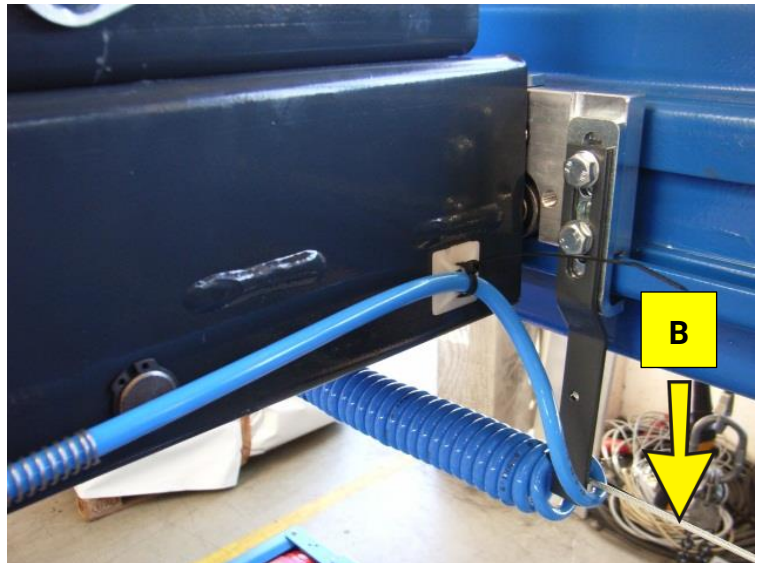
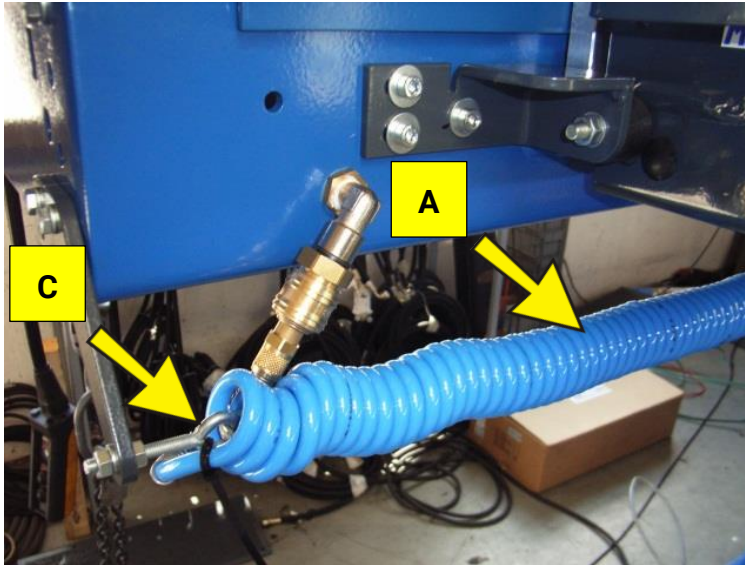

## 6.3 Park Position

### 6.3.1 Two Post Inground Lifts

- Fasten the switch flag including the withdrawal protection device (A) to the side piece.
- After positioning the limit switch (B), drill holes for the guide rail holding the fixture and the stop screw (C). Then install the rail.

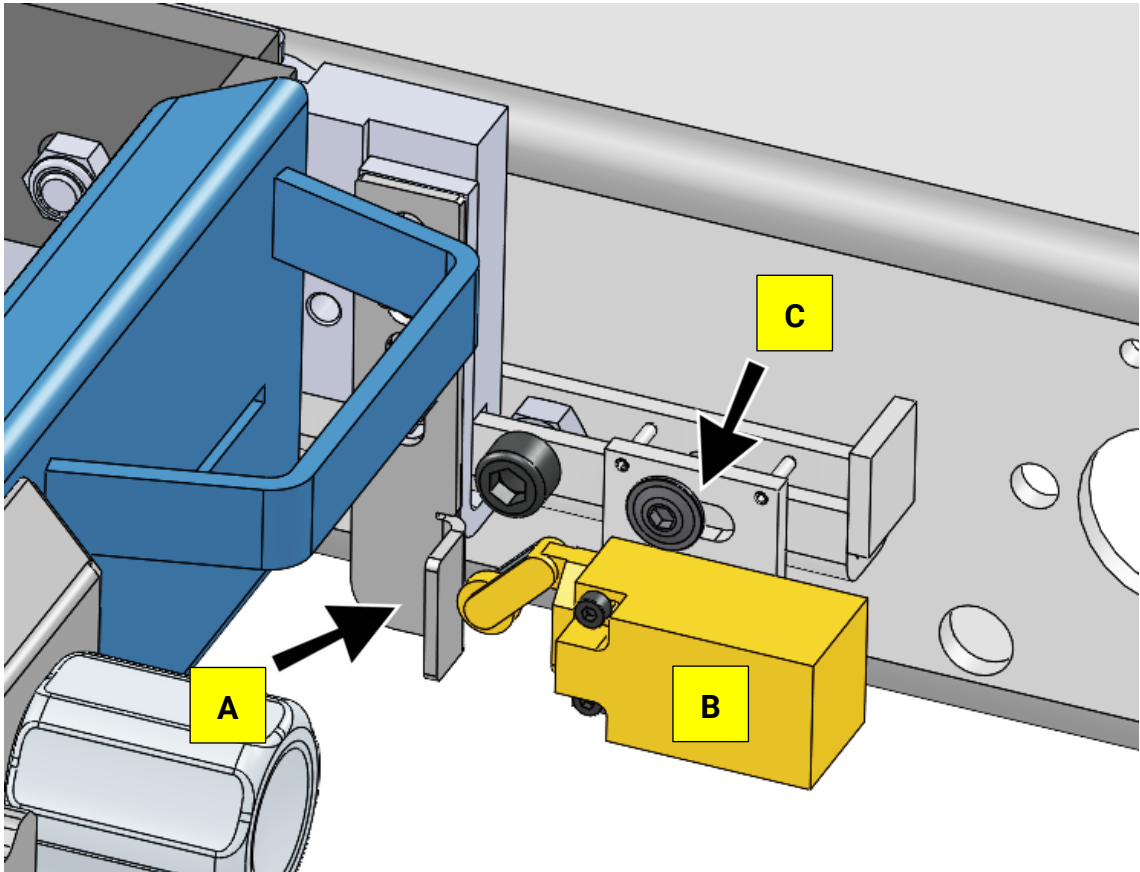

### 6.3.2 Four Post Inground Lifts

- Install the stop (A) including the withdrawal protection device to the side piece.
- Install the lock (B) and the limit switch (C) to the runway. Then install the proximity switch (D) with a distance of 2 to 4 mm to the switch flag and protect it against collision.

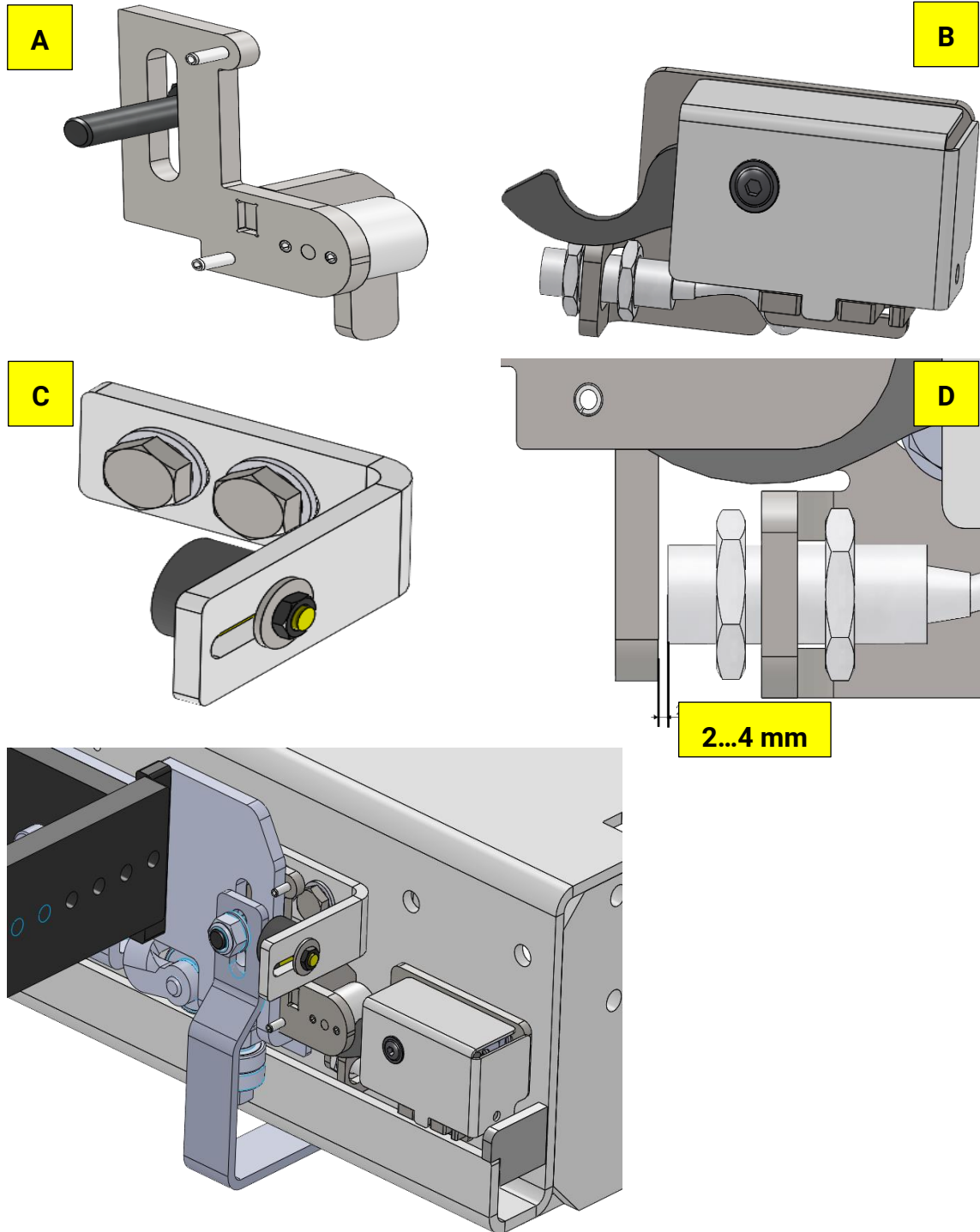

### 6.3.3 DUO

#### Required Tools

- Drilling machine / Cordless screwdriver
- Core hole drill Ø 5 mm (for M6)
- Tap M6
- Hex key A/F 7
- Hex key A/F 10
- Hex key A/F 13
- Hex key A/F 18
- Thread locker
- Allen key A/F 3
- Allen key A/F 5

#### Axle Jack Lock

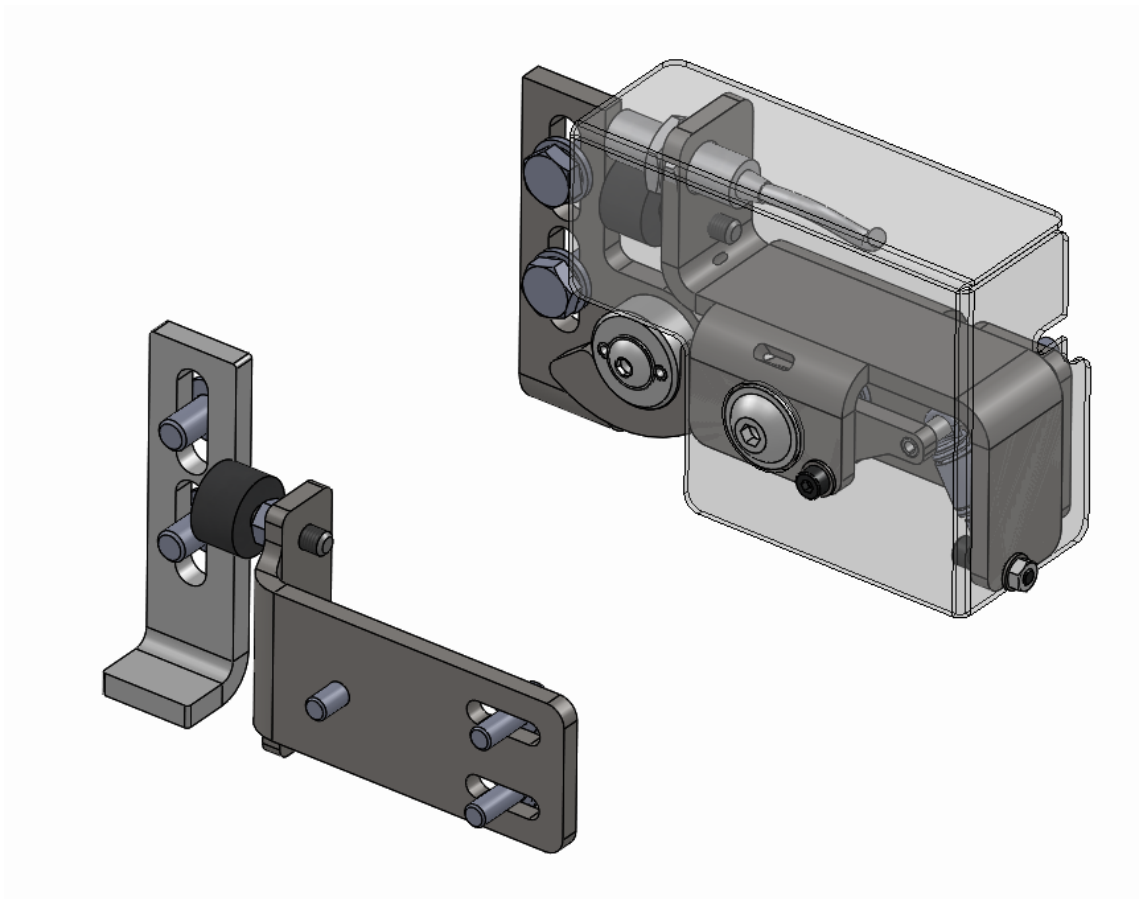

Liftout guard  
(L) = Left (R) = Right

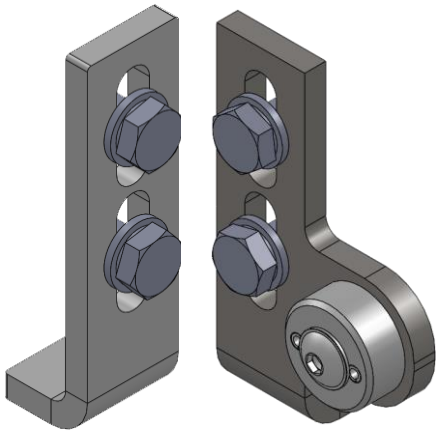

End stop  
(A) = Stop (B) = Lock

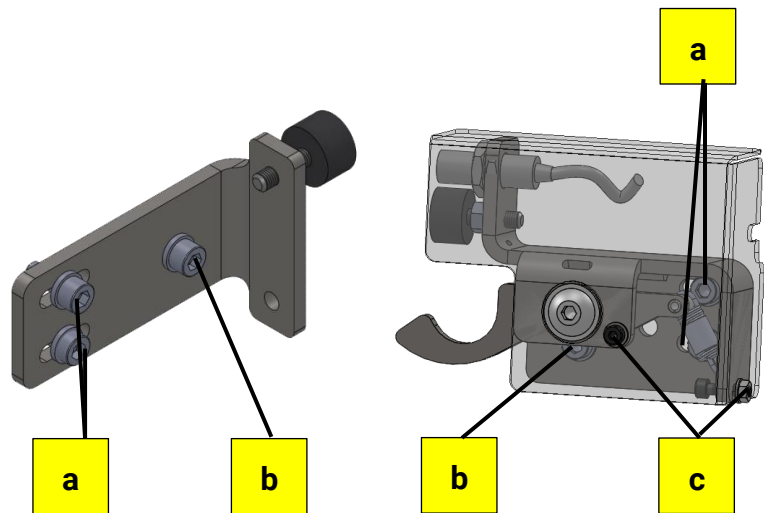

### Positioned Axle Jack

Left liftout guard, left (L) + Stop (A)

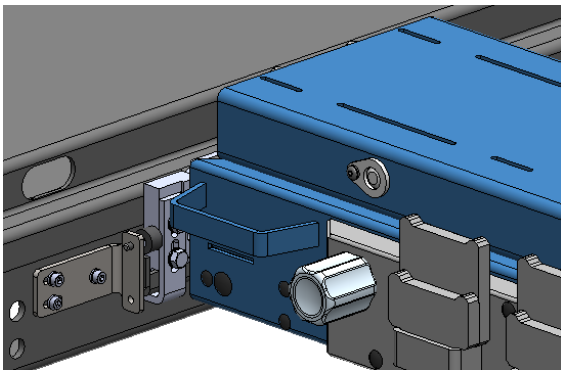

Right liftout guard (R) + Lock (B)

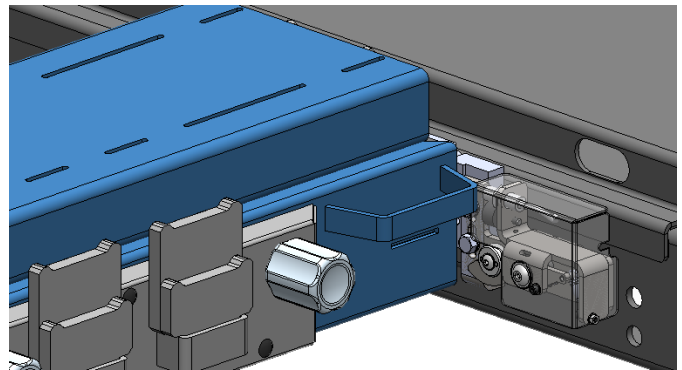

### Workflow (Initial Installation)

- 1 Install the lift.
- 2 Install the floor cover.
- 3 Mount the axle jack.
- 4 Replace the Right liftout guard (R) with the liftout guard premounted to the axle jack; see „Positioned Axle Jack“.



Replacement of the Right liftout guard (R) is necessary only on the side with the Lock (B)!

- 5 Position the premounted Lock (B) and Stop (A) so that the axle jack can be lowered into the floor cover/foundation without collision.  
→ Open screws (a) → Adjust (B) + (A) → Tighten screws (a).



The rubber buffers of lock (B) and stop (A) must bring the axle jack to a halt as far as possible simultaneously!

- 6 Install the proximity switch to the lock (B), connect and adjust it (see circuit diagram: 299.99.L05308).
- 7 Functional test.
- 8 Collision test.
- 9 Mark the position for screw (b) at the runway, drill and tap holes (M6).
- 10 Fix lock (B) and stop (A) with screw (b) and secure against loosening using a thread locker.
- 11 Secure screws (a) against loosening using a thread locker.
- 12 Mount the cover on the lock (B) and fix it using a screw and nut (c).

### **Workflow (Retrofitting)**

- 1 Remove the end stops to be replaced (left + right) and the limit switch.
- 2 Check: side parts must be installed centrally (symmetrically) to the axle jack.
- 3 Install Left (L) and Right (R) liftout guard, swap if necessary.



Replacement of the Right liftout guard (R) is necessary on the side with the Lock (B)!

---

- 4 Position the premounted Lock (B) and Stop (A) so that the axle jack can be lowered into the floor cover/foundation without collision.  
→ Open screws (a) → Adjust (B) + (A) → Tighten screws (a).



The rubber buffers of lock (B) and stop (A) must bring the axle jack to a halt as far as possible simultaneously!

---

- 5 Install the proximity switch to the lock (B), connect and adjust it (see circuit diagram: 299.99.L05308).
- 6 Functional test
- 7 Collision test
- 8 Mark the position for screw (b) at the runway, drill and tap holes (M6).
- 9 Fix lock (B) and stop (A) with screw (b) and secure against loosening using a thread locker.
- 10 Secure screws (a) against loosening using a thread locker.
- 11 Mount the cover on the lock (B) and fix it using a screw and nut (c).

## 7 Installation Procedure

### NOTICE

The axle jack may only be mounted in a suitable lift. The load capacity of the axle jack must not exceed 2/3 of the lift load capacity.

---

- 1 Lift the axle jack out of the packaging and place it at the desired height on suitable supports between the runways.

### NOTICE

The support plate and frame may only be lifted if the axle jack is tied together. Otherwise, the support plate is not supported by the cylinder and the axle jack will crash when releasing the safety stop.

---

- 2 Mount the side pieces including roller axles with rollers in the holes so that the axle jack is at the desired height. There are multiple choices for flange and roller axle mounting. The height can be varied by 12.5 mm by turning the black extensions in the axle jack (Fig. A).
- 3 Oil the roller axles while in mounted position.
- 4 Position in the guide rail of the runway or in the pit.
- 5 To secure against collapsing, drill an  $\varnothing$  8.5 hole on both sides directly outside the frame and mount with a bolt and nut (Fig. B).
- 6 Check all screws and nuts for tightness. Retighten if necessary.



### CAUTION

- Risk of personal injury and property damage
  - With danger of derailment additional safety measures are needed, especially with lift types as shown in Fig. C (synchronisation of runways!).
  - The safety technician must decide about the necessary safety measures for each individual case.
-



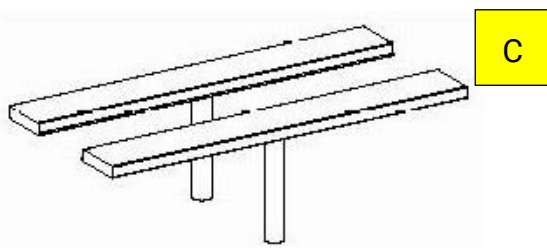
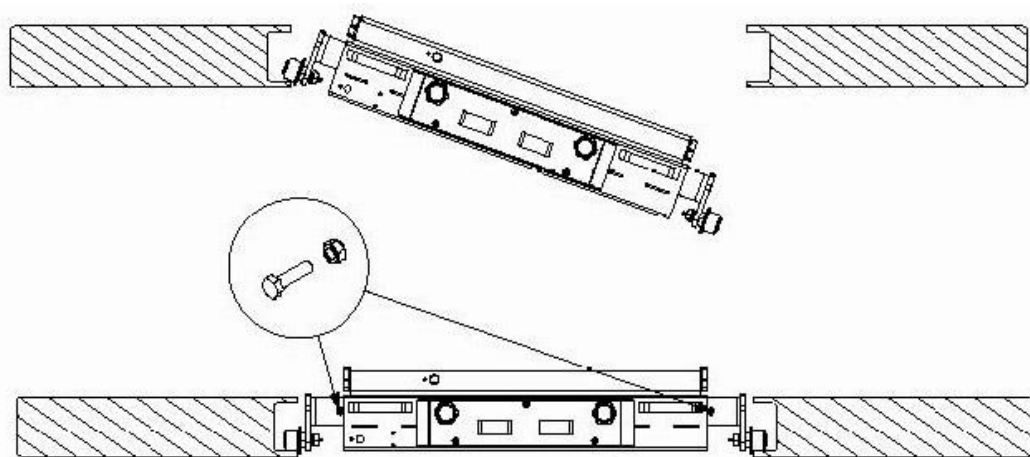
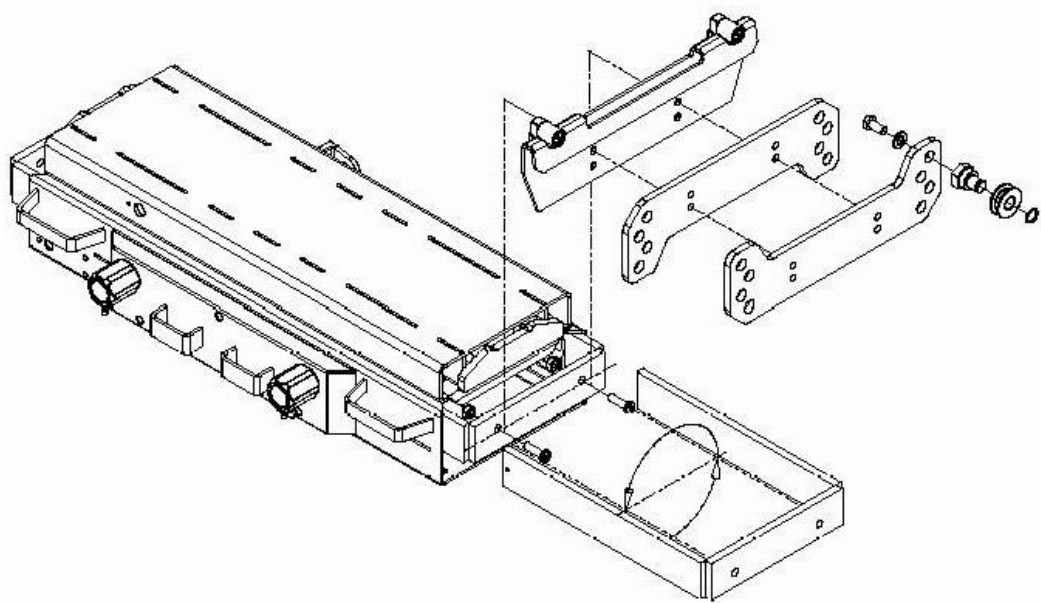



## 8

### Operation



#### CAUTION

#### Risk of personal injury and property damage

- Before each lifting procedure, check whether the running gear of the axle jack is correctly placed.
  - It is the operator's responsibility to make sure that operation represents no danger to persons.
  - The axle jack is to be used as lifting device only. Never transport the load using the axle jack.
  - Before working on the vehicle, lower the axle jack to nearest safety notch.
  - When lifting a vehicle with two axle jack units, they must have a minimum separation of 0.85 m.
- 

### 8.1 Operation of AL II 2.0 / 2.6

#### Raising

- 1 Use the pump lever.
- 2 After reaching the desired lifting height, turn the left-hand lever to the right to lower the axle jack to the nearest safety notch.

#### Lowering

- 1 Slightly raise the axle jack to release the safety lock.
  - 2 Turn both hand levers to the left.
- Left-hand lever is used for operating the trigger valve, right-hand lever for release of safety lock. Both levers return to the original position after release.

### 8.2 Operation of AL II 2.0 PH / 2.6 PH / 4.0 PH

#### Raising

- 1 Turn the left-hand lever to the left.
- 2 After reaching the desired lifting height, turn the left-hand lever to the right to lower the axle jack to the nearest safety notch.

#### Lowering

- 1 Slightly raise the axle jack to release the safety lock.
  - 2 Turn both hand levers to the left.
- Left-hand lever is used for operating the trigger valve, right-hand lever for release of safety lock. Both levers return to the original position after release.

## **8.3 Operation of AL II 2.6 PH W / 2.6 PH S**

### **Raising**

- 1 Turn the left-hand operating handle in a clockwise direction.

### **Lowering**

- 1 Verify that there is no danger of pinching.
  - 2 Actuate button on the box.
- Arms are retracted automatically, when axle jack reaches preset height.  
Height can be set by adjusting the corresponding valve.

### **Manual Lowering**

- 1 Turn both operating handles in a counterclockwise direction.
- Unloaded arms are retracted automatically, when axle jack reaches preset height.

## **8.4 After Usage**

- 1 Lower the axle jack into bottom position.
- 2 Remove the extenders and hang them up at the holders provided.
- 3 Move the axle jack to its defined park position in order to avoid damage.

## 9 Maintenance



**DANGER**

**Risk of death or severe personal injury by electric shock**



Before doing any maintenance work, turn off the main switch and protect it against tampering.

### 9.1 Maintenance Schedule

Interval	Maintenance points	Procedure
Daily	Axle jack and supports	Visual check.
Monthly	Mechanical parts	Grease all mechanical parts.
3 months	Hydraulic system	Check fluid reservoir and top up if necessary.
		Check hydraulic system for leakage.
		Check condition of sealing sleeves, replace if necessary.
		Check pump for unusual noise during operation, check fastening screws for firm fit.
6 months	Hydraulic fluid	Check fluid for dirt and aging, replace if necessary.
12 months	General inspection	Check all components for damage.

## 9.2 Annual Inspection



- The maintenance interval prescribed by the manufacturer is **12 (twelve) months**. This maintenance interval refers to normal workshop usage. If the equipment is used more frequently or under severe operating conditions (e.g. outdoors), the interval must be reduced accordingly.
  - Maintenance work shall be done only by authorised and trained service technicians provided by the manufacturer, licensed dealers or service partners.
  - In case of non-compliance the manufacturer's warranty becomes void.
- 

## 9.3 Care Instructions

- Periodically clean the equipment and treat it with a care product.
- Repair damage to the paintwork immediately to prevent corrosion.
- Do not use caustic cleaning agents or high pressure and steam jet cleaners to avoid equipment damage.



Regular care and maintenance is the key condition for functionality and long life expectancy of the equipment!

---

## 9.4 Refilling with Hydraulic Fluid

- 1 Raise axle jack to maximum height.
- 2 Remove filling plug.



### CAUTION

Do not turn the release lever as long as the filling plug is removed. Fluid reservoir is put under pressure!

- 
- 3 Fill hydraulic fluid up to the hole of the fill screw.



The filling quantity is 0.6 l. Use hydraulic fluid with viscosity ISO VG 15.

- 
- 4 Re-attach filling plug.

## 9.5 Troubleshooting

Error	Diagnosis	Remedy
Axle jack does not raise to the desired height.	Fluid level too low.	Re-fill hydraulic fluid.
	Axle jack locked.	Check whether the safety stop lever is in neutral position and can be freely moved.
Axle jack cannot be completely lowered.	Axle jack damaged or rough-running.	Check for damage, oil mechanical parts.
Axle jack continues to lower although the safety stop lever has been released.	Air in hydraulic system.	Bleed the hydraulic cylinder in unloaded condition.

## 9.6 Spare Parts

To ensure safe and reliable operation, only use original spare parts supplied by the equipment manufacturer.

## 9.7 Hydraulic Diagram

AL II 2.0 / 2.6

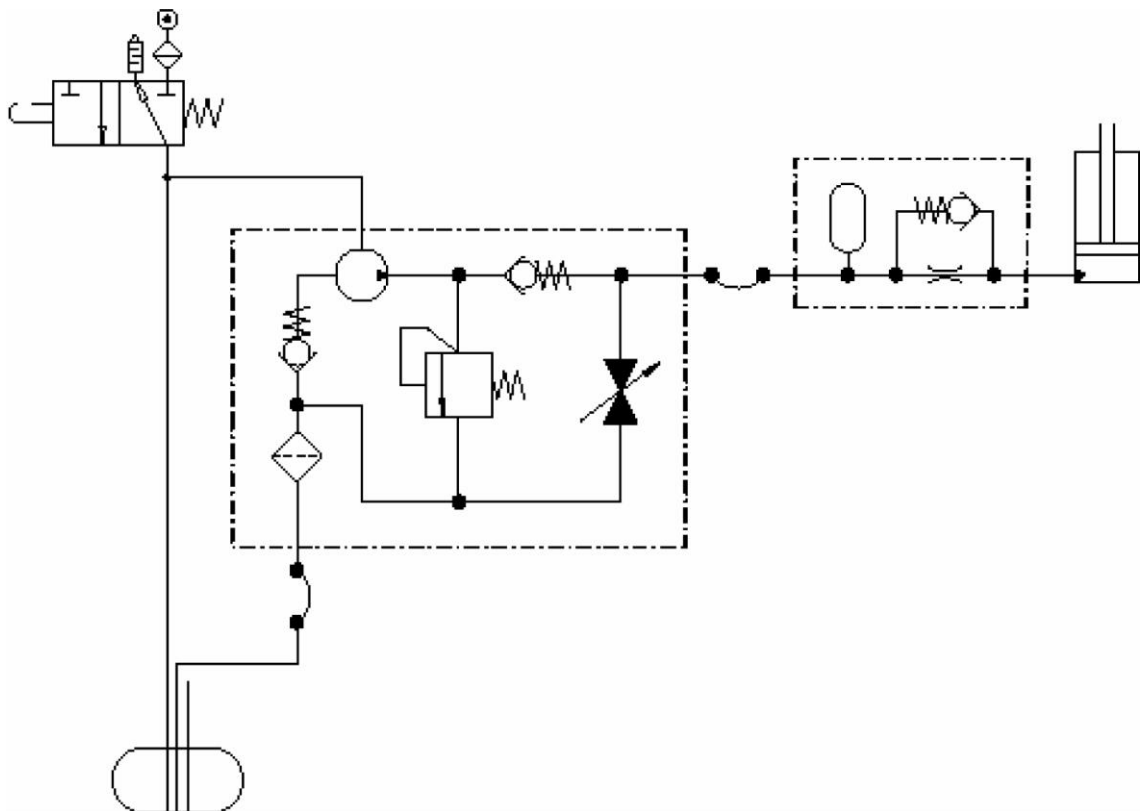
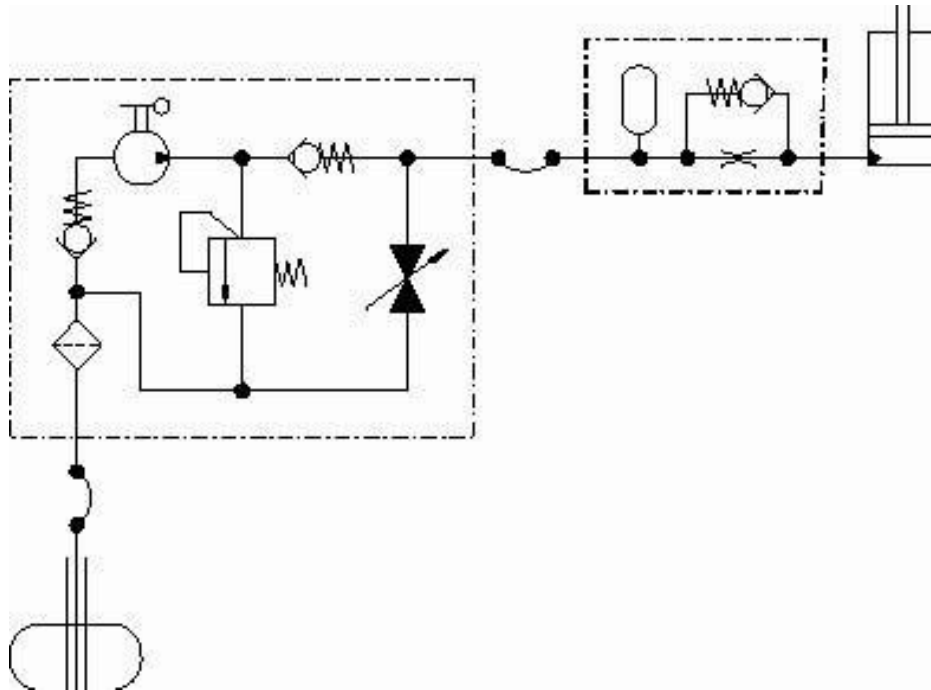

AL II 2.0 PH / 2.6 PH / 4.0 PH

## 10 Service Lifetime

In its standard version, this product is designed for 22,000 load cycles based on EN 1493. The maximum period of normal use in relation to the possible product life expectancy shall be evaluated and scheduled by a qualified person during the annual safety inspection.

## 11 Dismantling

Decommissioning and dismantling of the equipment may be done only by specially authorised and trained personnel provided by the manufacturer, licensed dealers or service partners.

## 12 Disposal

If you want to dispose of the equipment, please contact your MAHA dealer or the following address, indicating equipment type, date of purchase and serial number:

MAHA Maschinenbau Haldenwang GmbH & Co. KG  
Hoyen 20 | 87490 Haldenwang | Germany

Phone: +49 (0) 8374 585 0

Fax: +49 (0) 8374 585 500

Email: info@maha.de

Alternatively, you may take the equipment to a specialised waste management plant to ensure that all components and operating liquids are properly disposed of.

## 13 Contents of the Declaration of Conformity

### MAHA Maschinenbau Haldenwang GmbH & Co. KG

herewith declares as a manufacturer its sole responsibility to ensure that the product named hereafter meets the safety and health regulations both in design and construction required by the EC directives stated below.

This declaration becomes void if any change is made to the product that was not discussed and approved by named company beforehand.

**Model:** AL II 2.0 / AL II 2.0 PH  
AL II 2.6 / AL II 2.6 PH / AL II 2.6 PH W / AL II 2.6 PH S  
AL II 4.0 PH / AL II 2.8 PH W MB / AL II 4.0 PH W MB

**Designation:** Axle Lift; Rated Load Capacity 2000 / 2600 / 4000 kg

**Directives:** 2006/42/EC

**Standards:** EN 1494

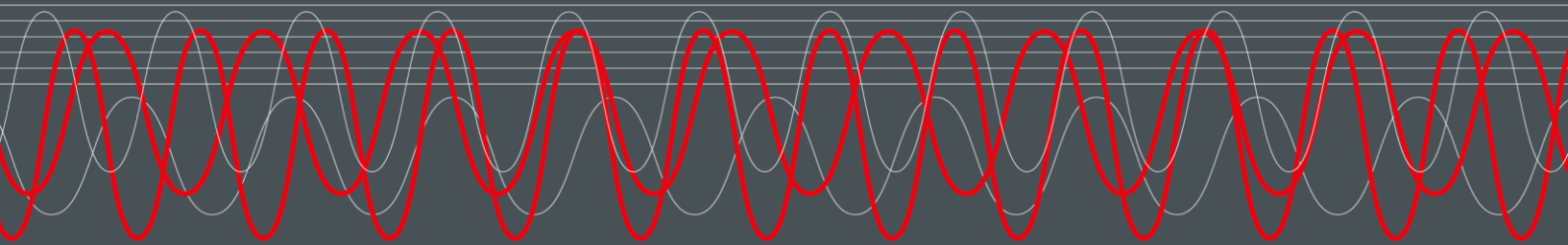

**MAHA MASCHINENBAU HALDENWANG GMBH & CO. KG**

Hoyen 20  
87490 Haldenwang  
Germany

☎ +49 8374 585 0  
✉ [maha@maha.de](mailto:maha@maha.de)  
🌐 [maha.de](http://maha.de)